

CURE PUCK



CURE **PUCK**

USER MANUAL

PN: 21-10258_REV06

TWISTERTECH.IO



TABLE OF CONTENTS

Installation	
Barrel	2
Bin	3
Screen Icons	
Home	4
Settings	4
Auto Cure	5
Alert limits	5
Air Exchange	5
Advanced	6
Internet Connection	7
Quick Start Guide	8
Frequency / Duration / RH Mode	11
Alerts	13
CO2 Calibration	14
Starting The Cure	15
VPD: The Plant's Breathing Process	17
Difference Between a Growing Plant and a Cut Plant	18
Cure Puck App	
Android Installation	19
Iphone Installation	24
Router Suggestion	28
More Settings	
Manual Burp Control	29
Notifications	29
Reconfigure vs WiFi Provision Mode	31
Reset to Factory Settings	33
Appendix A	
What is Relative Humidity %RH	34
What is Vapor Pressure Deficit VPD (kPa)	35
Putting it All Together VPD Autocure	36
Relative Humidity Autocure Mode	38
%RH vs VPD AutoCure conclusions	39
Room Conditions	40
Hydrate Mode - AutoCure	41
Appendix B	
Example VPD Set Points	42
VPD calculator	43
VPD vs Temperature vs %RH	44

INSTALLATION

BARREL

a. The threads on the CurePuck match the threaded openings on many barrels. The Cure Puck can be threaded directly into the opening of these barrels.

b. If you need to drill a hole in your drum, create a hole using a 2 3/8", 2 1/2", or 60mm hole saw. Check to make sure the Cure Puck will sit flush without the sensor probes hitting anything. We recommend a location as high as possible.

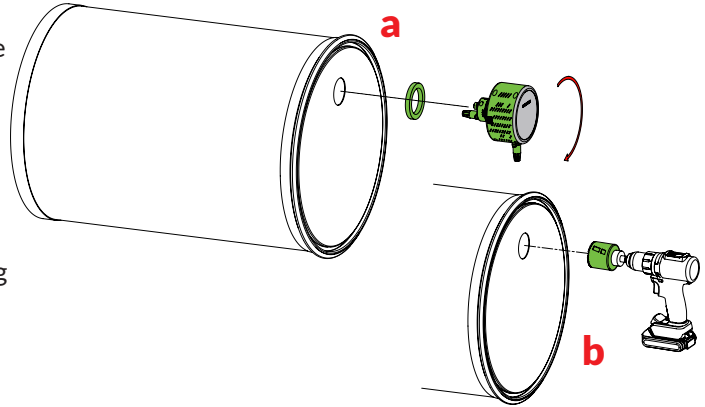

STEP 1

Remove the Threaded Nut (1) from the Cure Puck body leaving the Chamber Gasket, (2) on the Cure Puck.

Insert the CurePuck in the hole with the Chamber Gasket between the body of the CurePuck and the barrel lid. Thread the nut finger tight with enough force to compress the gasket 3/16" (5mm).

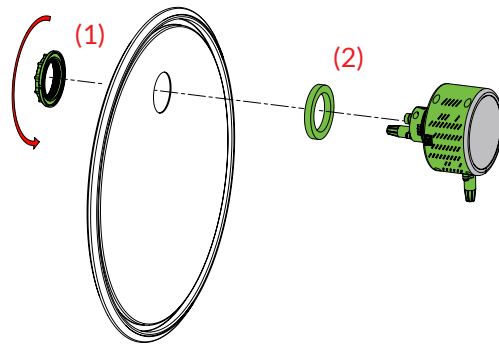

STEP 2

a. Cut the tubing to length so that the diffuser (1) lays as shown. Insert the Diffuser Assembly into the Cure Puck.

b. Ensure the fill level of the flower does not bury the sensor probe on the CurePuck!

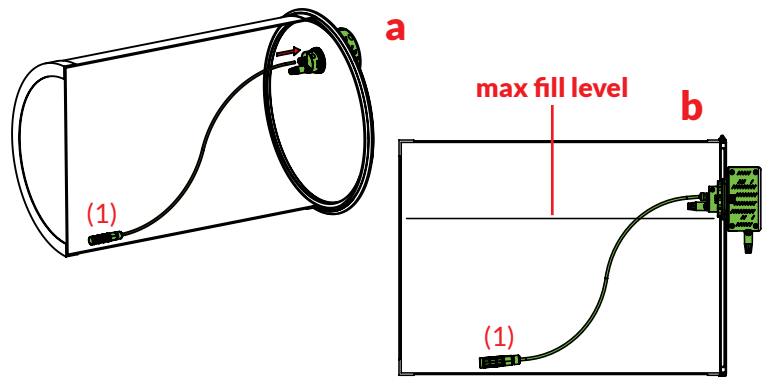

STEP 3

BIN

Create a hole using a 2 3/8", 2 1/2", or 60mm hole saw. Check to make sure the CurePuck will sit flush without the sensor probes hitting anything. We recommend a location as high as possible.

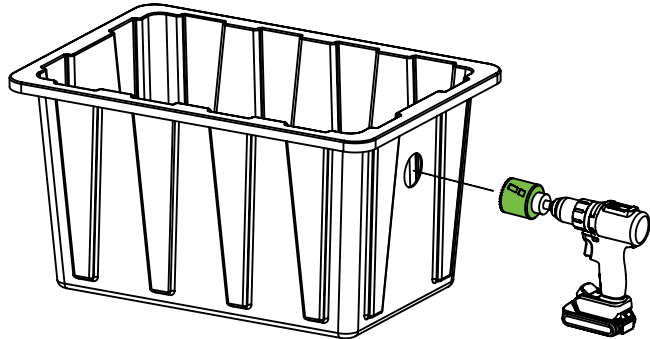

STEP 1

a. Remove the Threaded Nut (1) from the CurePuck body but leave the Chamber Gasket (2) on the Cure Puck.

b. Insert the CurePuck with the Chamber Gasket between the body of the CurePuck and the bin. Thread the Nut finger tight with enough force to compress the gasket 3/16" (5mm).

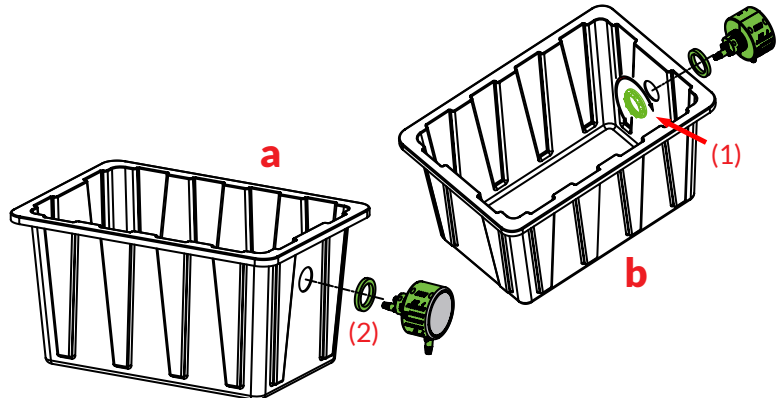

STEP 2

a. Cut the tubing to length so that the diffuser (1) lays as shown. Insert the Diffuser Assembly into the Cure Puck.

b. Ensure the fill level of the flower does not bury the sensor probe on the CurePuck!

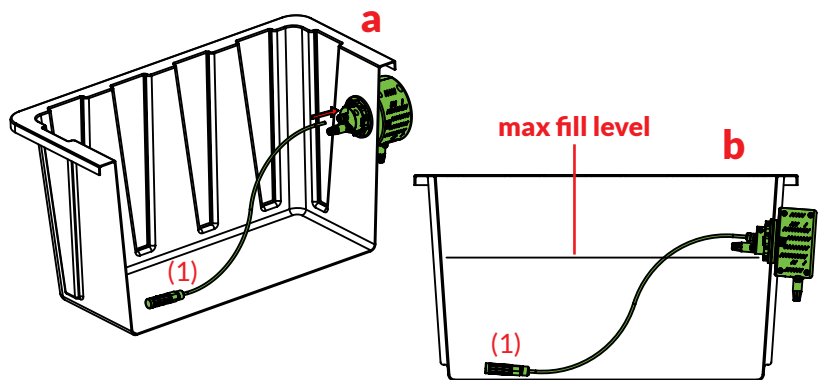

STEP 3

SCREEN ICONS

1. Home

- a. Battery- Displays one to four bars to indicate battery charge level
- b. Wi-Fi- Displays one to three bars to indicate signal strength when connected to internet
- c. Alert- Tap this icon to display alerts. Flashes RED when an alert is active
- d. Settings- Tap this icon for Settings
- e. Container %RH- Current Relative Humidity in the container
- f. Container CO₂- Current CO₂ level in the container in parts per million (PPM)
- g. Timer- Tap to Start or Stop the Air Exchange Frequency Timer
- h. Pump- Tap to Start or Stop a burp cycle
- i. Room %RH- Current Relative Humidity in the room
- j. Room Temperature- Current Room Temperature
- k. Status- Home Icon, Information, or Timers
- l. Cure Puck Name

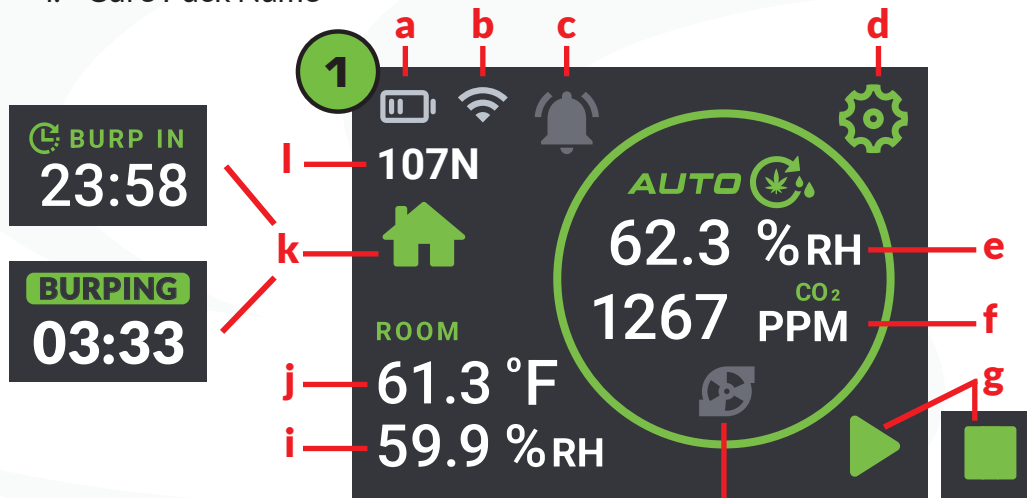

2. Settings

- a. Software Version
- b. Home- Return to Home Screen
- c. Page Name
- d. Advanced- More Settings
- e. Cure Puck Name
- f. Network- Connect to Network Settings

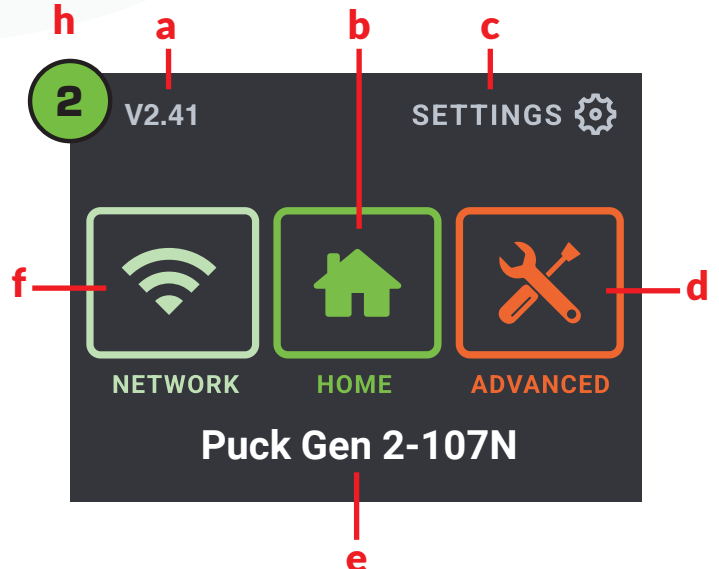

3. Settings > **Auto Cure**

- Autocure Mode On/Off and VPD Setting - Tap to turn On/Off and set values
- Cure Duration- Tap to turn On/Off and set value
- CO₂ Exchange- Tap to turn On/Off and set value
- Next - Go to next settings page
- Help/Reset- Tap to go get QR code for help files and instructions on factory reset
- Back- Return to previous menu

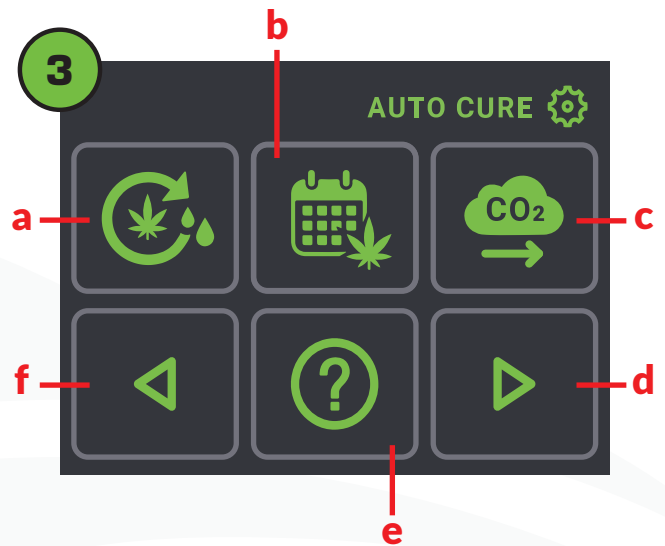

4. Settings > **Alert Limits**

- Room High Temp- Tap to turn On/Off and set value
- Room High Relative Humidity- Tap to turn On/Off and set value
- Container Relative Humidity (Flower Too Wet)- Tap to turn On/Off and set value
- Next- Go to next settings page
- Room Low Relative Humidity-Tap to turn On/Off and set value
- Back- Return to previous menu



5. Settings > **Air Exchange**

- Air Exchange Start Limit- Tap to turn On/Off and set value
- Air Exchange Frequency- Tap to set value
- Air Exchange Stop Limit- Tap to turn On/Off and set value
- Next- Go to next settings page
- Air Exchange Duration- Tap to set value
- Back- Return to previous menu

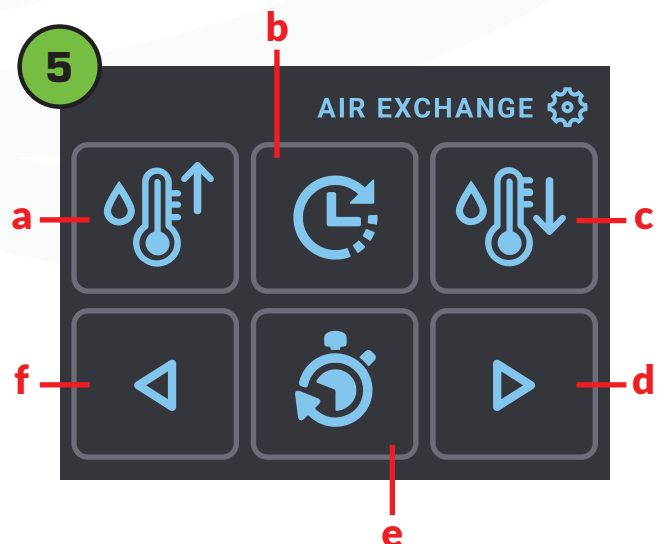

SCREEN ICONS

6. Settings > **Advanced**

- a. Sleep- Tap to display sleep settings
- b. °C- Tap to display temperatures in Celsius
- c. Live Sensors- Tap to display all sensors in real time
- d. Next- Go to next settings page
- e. °F- Tap to display temperatures in Fahrenheit
- f. Back-Return to previous menu

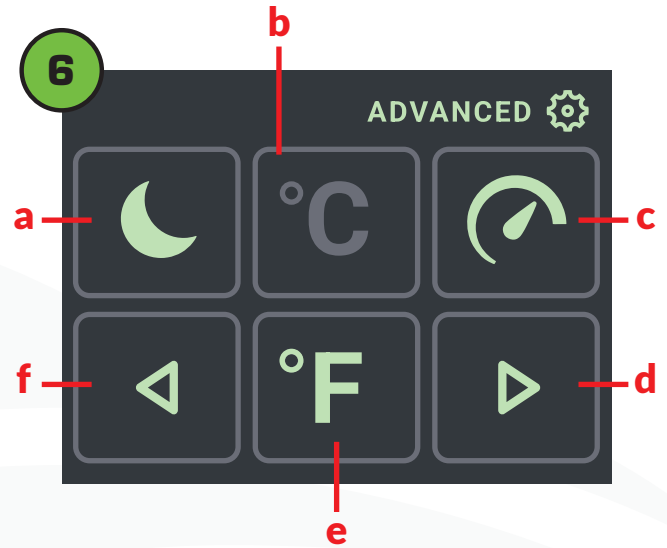

INTERNET CONNECTION

CURE PUCK APP

See Android (pg 19) or iPhone (pg 24) Connection Manuals

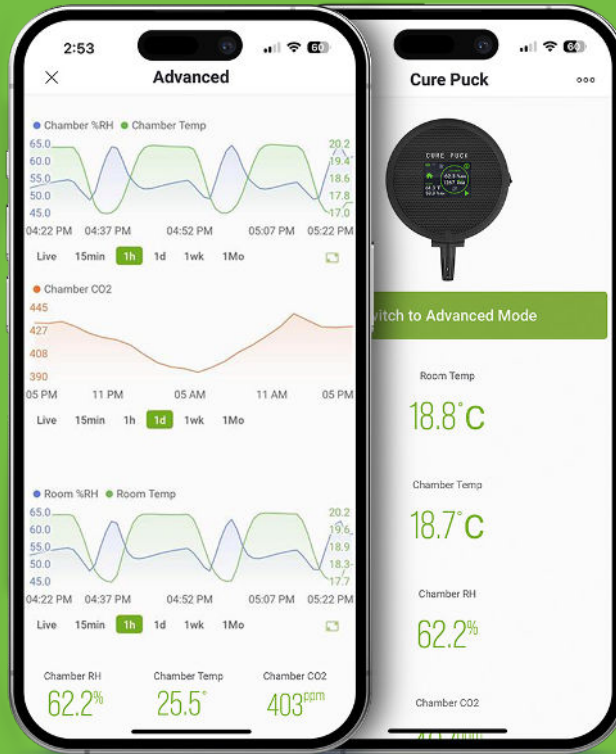

AVAILABLE ON



Download on the
App Store



GET IT ON
Google Play

! A smart phone is needed only for setting network information and linking the Cure Puck to your Cure Puck account. The data from all your Cure Pucks can then be accessed through the Smart Phone App and **Web Portal** at <https://dashboard.curepuck.io/> using the same login.

QUICK START GUIDE

QUICK START

CurePuck now comes with an advanced PID algorithm that uses the concept of **Vapor Pressure Deficit**, known as **VPD**. VPD combined with our unique FunkGuard allows easy and safe curing!

It is important to understand the concept of VPD; see **Appendix A** (pages 34-41) for a full explanation of VPD and how it applies to curing and drying. For guidance on establishing an appropriate VPD setpoint using the online **VPD calculator** see page 43.

Although your Cure Puck still allows time and humidity based curing, we recommend using the VPD method in AutoCure mode. To start AutoCure mode, follow these steps.

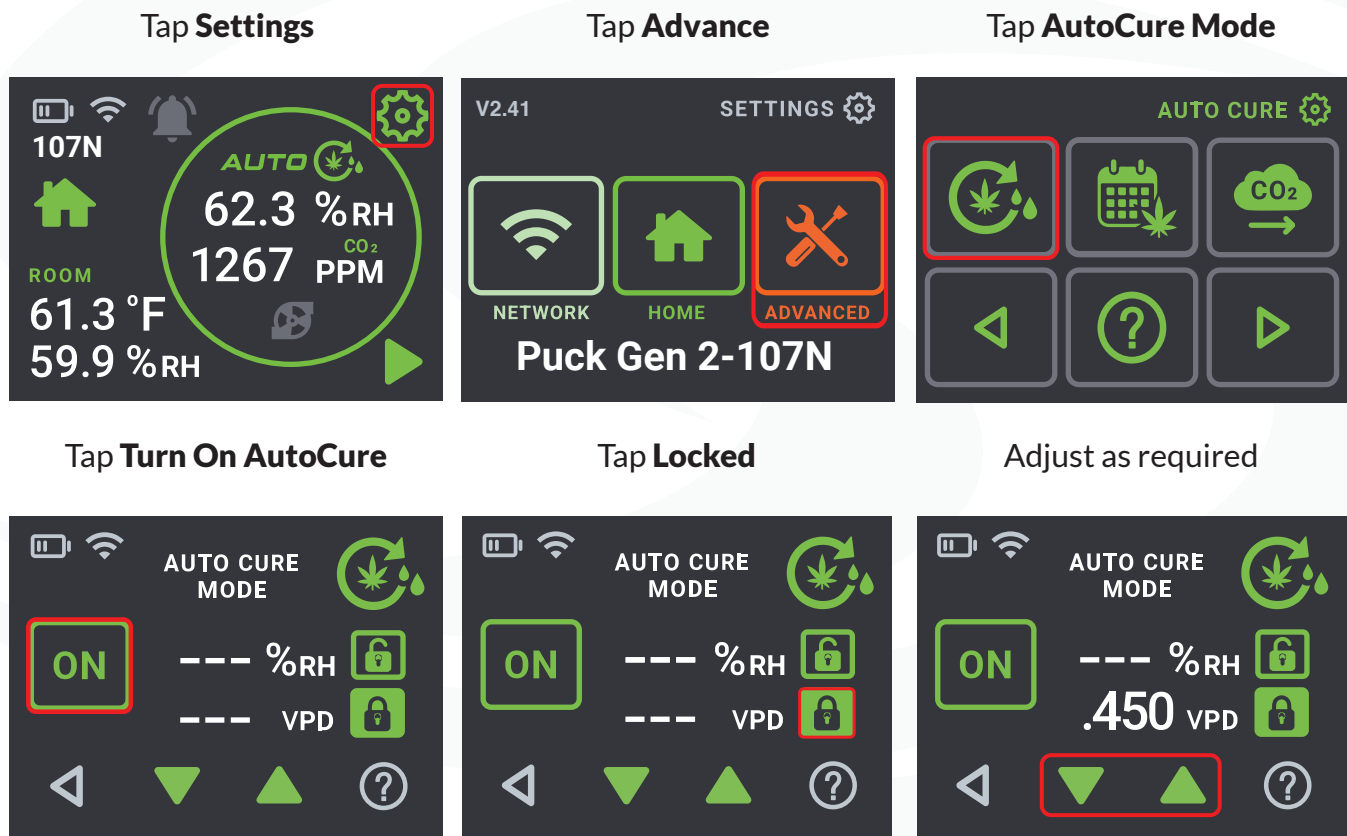

Image 5

AutoCure can operate in two modes, Relative Humidity (%RH) mode or Vapour Pressure Deficit (VPD) mode. Tap the lock symbols so that the locked symbol is shown next to “VPD”. %RH and VPD both aim to hit the the locked setpoint.

The VPD setting depends on your expected room temperature range. Detailed in **Appendix A**.

QUICK START GUIDE

Tap **Back**

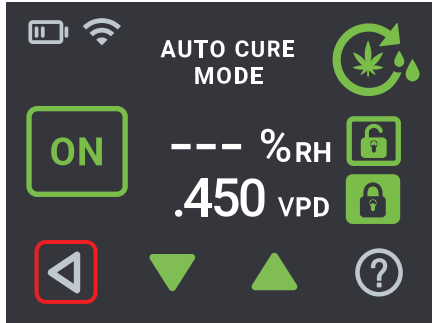

Tap **Cure Duration Calendar**

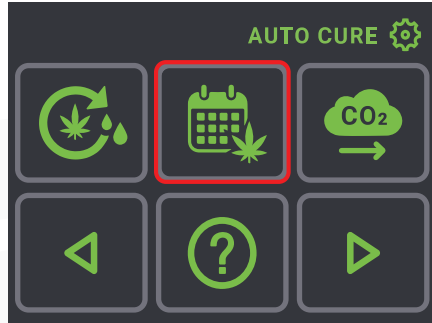

Tap **Off** to turn on

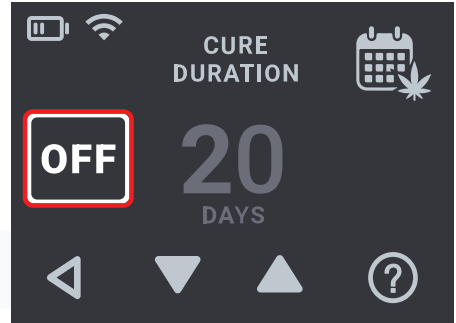

Adjust as required
This disables timed burps after
xx days

(This page will be displayed
when you cure cycle is
complete)

Tap **Back**

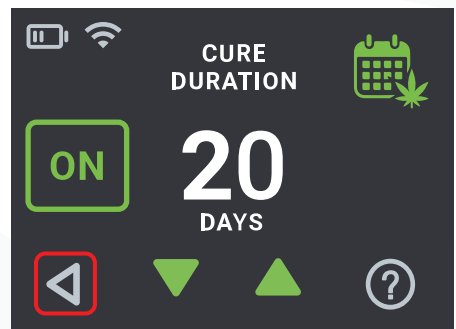
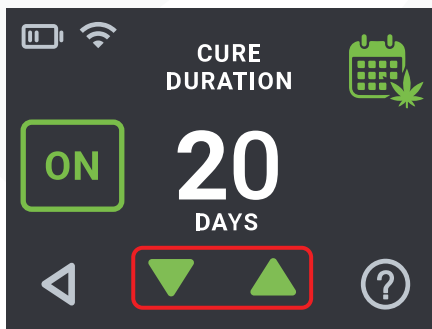

Tap **CO₂ monitoring**

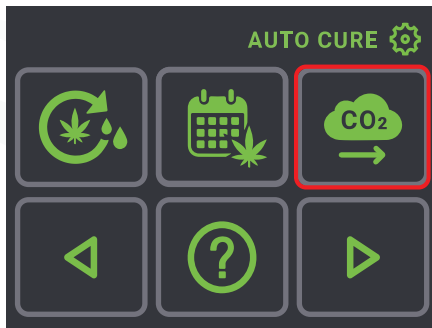

Tap **Off** to turn on

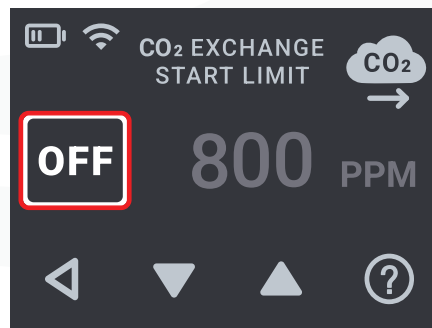

Adjust as required

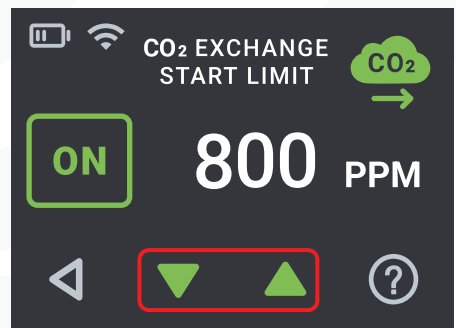

Image 7

The accumulation of excessive CO₂ can occur in the chamber during the curing process. If CO₂ monitoring is active and the Chamber exceeds the set point a burp will occur. A burp is defined by the duration setting. For example if duration is set to 30mins, then one burp will be 30mins.

Image 9

Adjust the setting to between 800 and 1200ppm. Excessive CO₂ can produce a funky smell and taste to your cannabis. With the Cure Puck monitoring CO₂ it will trigger a burp to remove accumulated CO₂ when this limit is exceeded.

QUICK START GUIDE

Tap **Back**

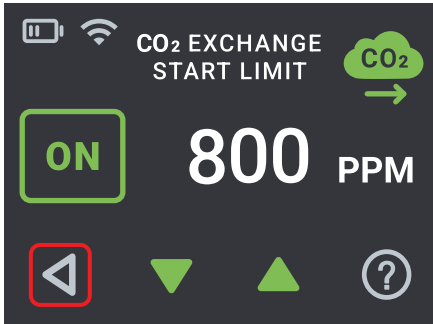

Tap **Back**

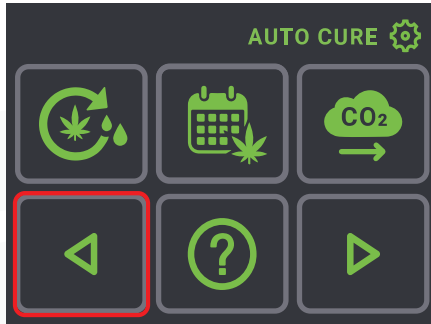

Tap **Home**

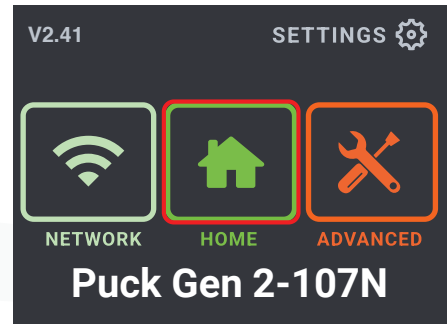

AutoCure symbol now visible!

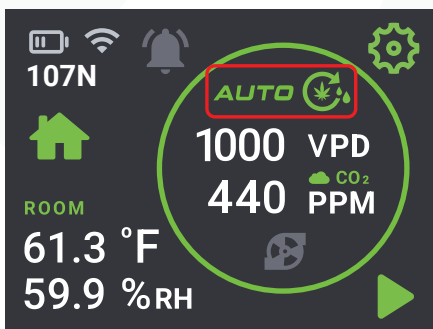

Tap **Play**

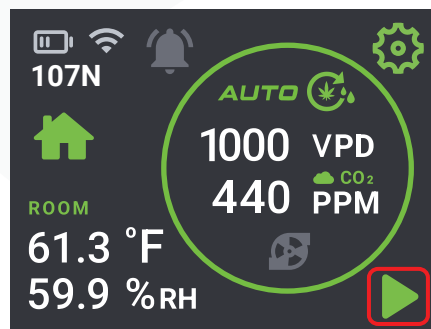

The home screen will now display the estimated time before the next burp

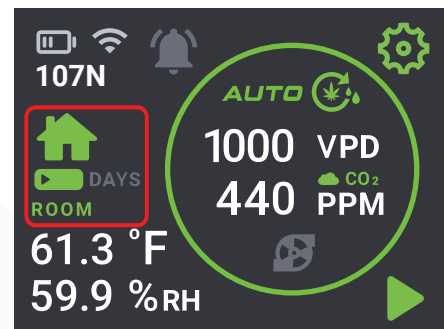

Now sit back and relax while the CurePuck watches over your product. You are on your way for amazing cure! Note: When AutoCure is enabled, even if the play button is not pressed, it will still cure in AutoCure mode. The play button just turns on the timed burps according to duration and frequency settings.

Optimizing Room Conditions for best results.

Your CurePuck exchanges air between the curing container and the room. For best results it is important to have the room within humidity and temperature limits. Aim for a room relative humidity of less than 55%RH and a temperature between 16 - 18°C (61° - 64°F). The CurePuck doesn't contain an active dehumidifier, it can only use fresh air from the room to slowly bring down the moisture of the flower, if the room is too wet, such as wetter than your target setpoint, it is not physically possible for the CurePuck to remove moisture and hit the target %RH. See Appendix A for details on room conditions.

FREQUENCY / DURATION / RH MODE

The CurePuck uses three main settings to control your cure.

1. Air Exchange Frequency - This is a timer, the Burp starts when the timer expires.
2. Air Exchange Start Limit - The CurePuck monitors the Relative Humidity in the container and will start a Burp when the Relative Humidity of the container exceeds the programmed limit and the Air Exchange Start Limit is ON.
3. Air Exchange Duration - This is a timer that determines the duration of a burp cycle.

These three setting can be used independently or together.

Example program

Burp every 24 hours and if required, burp when the relative humidity in the container exceeds 64%.

Set Air Exchange Frequency to 24 hrs.

Set Air Exchange Start Limit to ON and adjust the value to 64%.

A burp activated by the Air Exchange Start Limit will not reset the Air Exchange Frequency timer.

You start the Air Exchange Frequency Timer at 10am, the CurePuck will burp every 24 hours. If the humidity in your container gets higher than the Air Exchange Start Limit Set Point 64% at 2am then the Cure Puck will burp at 2am and again at 10am. The CurePuck will continue to burp the container as scheduled every 24 hours at 10am.

Tap **Settings**

Tap **Advance**

Tap **Next**

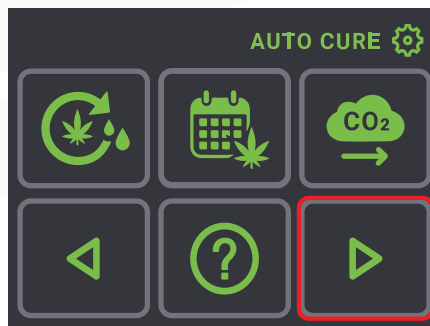
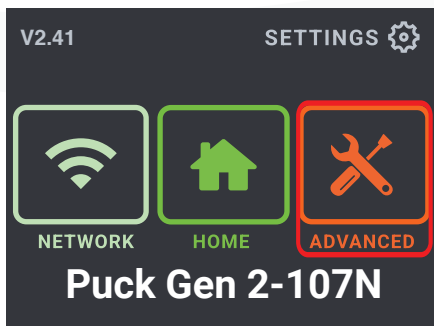
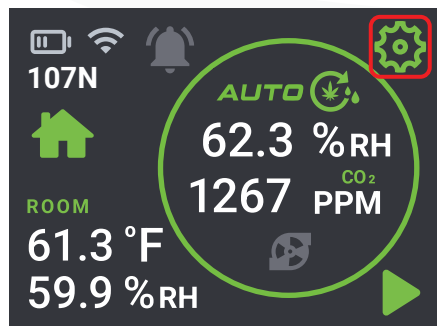

FREQUENCY/DURATION/RH MODE

Tap **Next**



Tap **Air Exchange Frequency**

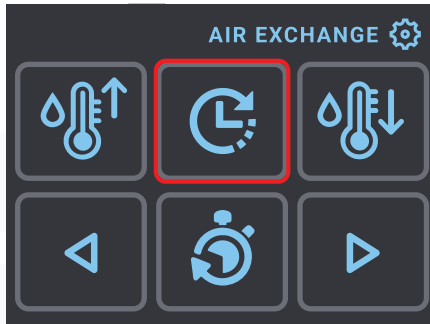

Adjust as required

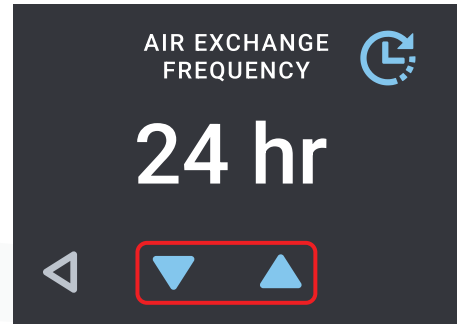

Tap **Back**

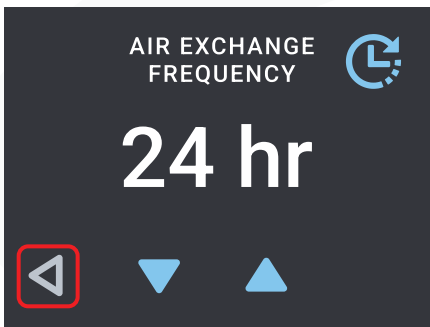

Tap **Air Exchange Start Limit**

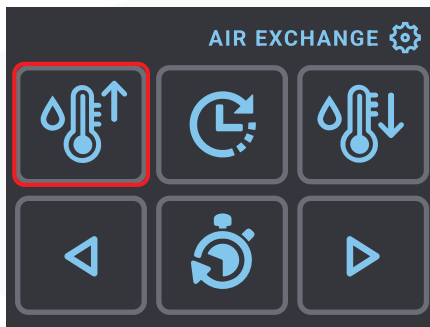

Tap **Off** to turn on

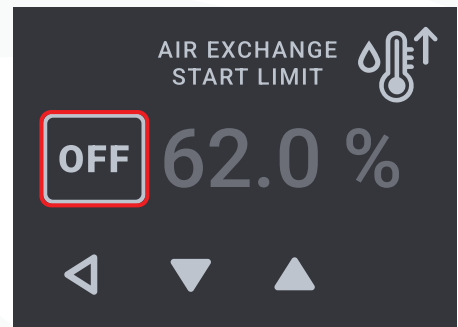

Adjust as required

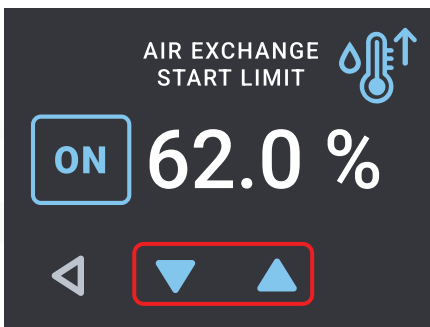

Tap **Back**

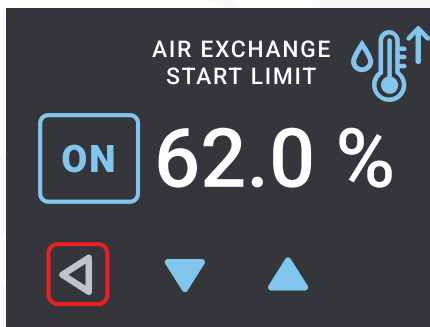

Tap **Air Exchange Duration**

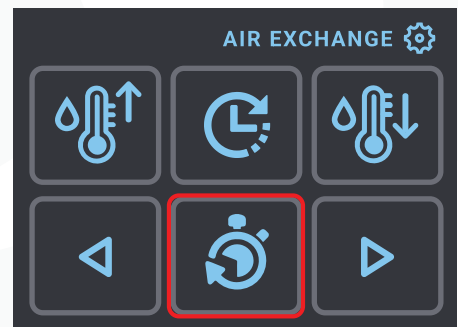

Adjust as required

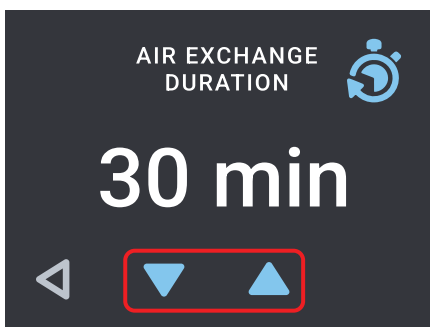

Tap **Back**

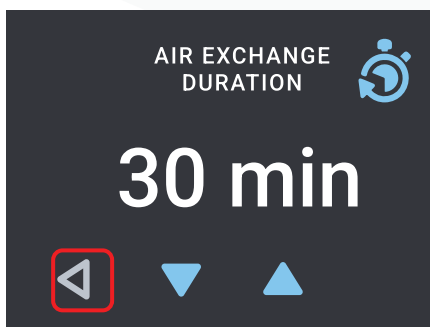

ALERTS

Cure Puck will display the Alert icon RED when an Alert is active.

Tap **Back**



Tap **Room High Temp**



Tap **Off** to turn on

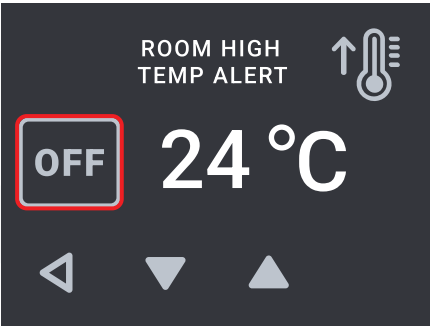

Adjust as required

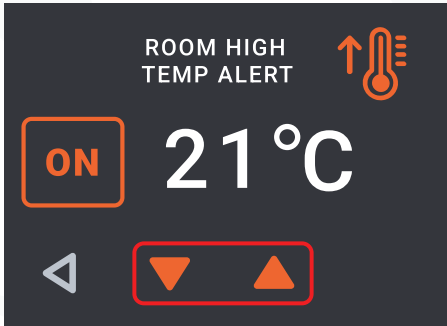

Tap **Back**

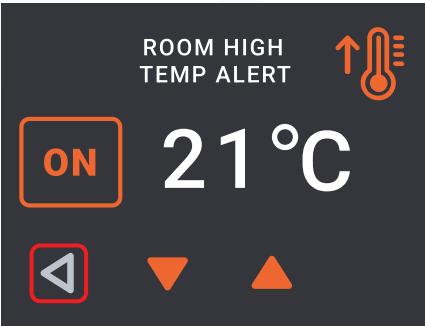

Tap **Flower Too Wet**



Tap **Off** to turn on

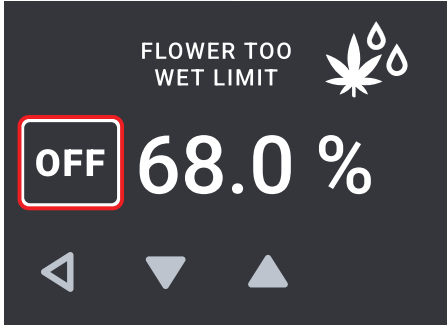

Adjust as required

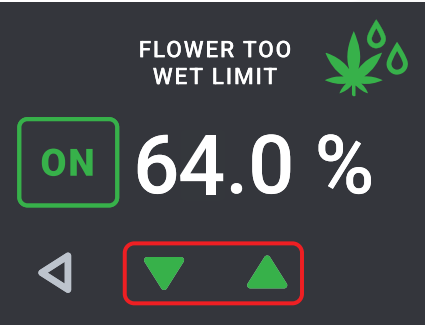

Tap **Back** x 3

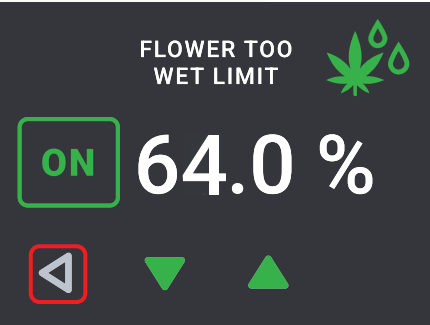

CO2 CALIBRATION

CO2 CALIBRATION

This step is necessary to calibrate the CO2 sensor to 400 ppm for the current environment and must be done every 6 months.

Follow the steps below to calibrate the CO2 sensor.

Tap Settings

Tap Advance

Tap Next

Tap Next

Tap Next

Tap Live Sensors

Tap Down

Tap CO2

Wait for next step

1-Place the device in a fresh air environment for 20 minutes.

2-After 20 minutes in fresh air: Go back inside the room and quickly tap **Yes** while holding your breath for 7 seconds.

Note: Do not breathe near the sensor during calibration. It is very sensitive and may cause an offset error. Calibration takes ~7 seconds.

Once the screen sensor reads **400 PPM**, the calibration is complete.

STARTING THE CURE

Relative humidity changes with temperature. For every 1°C difference, a 5% difference in RH is observed. It is extremely important to keep the cure bins in a consistent environment. If you move the bin to a room with a different temperature, it could take over an hour for the readings to stabilize.

1. Start by inspecting your flower in the dry room and determine if it's ready to cure.
 - a. Take some samples of various bud sizes and fill up an airtight container/bag with flower, along with an accurate humidity meter. A CurePuck on a small glass jar can also be used as a high accuracy way to measure the equilibrium head space humidity of the sample.
 - b. Wait at least 30 minutes, or until the %RH reading has stabilized.
 - c. If the RH meter reads 61-64%, the flower is ready for the cure bin. (This value will vary by strain for best results, 63% is good start, too moist and you can get a grassy smell).
2. With the CurePuck installed and programmed, fill the bin to the recommended fill level.
 - a. **Never bury the Cure Puck with Flower.**
 - b. Locate difusser (1) as shown below.

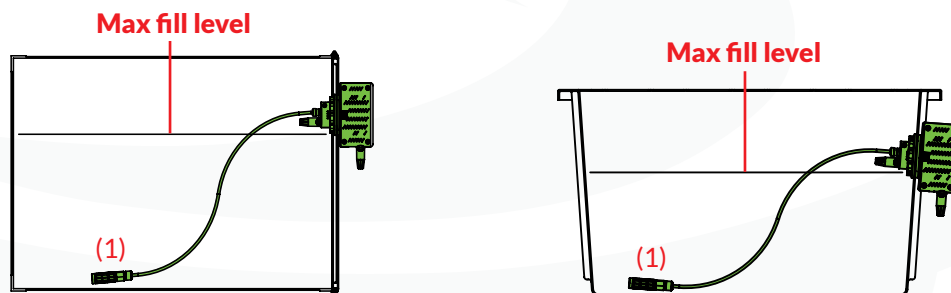

3. Connect the Cure Puck to Power (1) and Switch On Power (2).

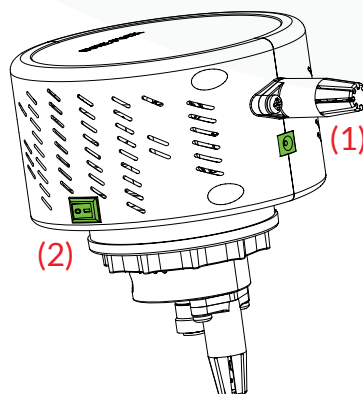

STARTING THE CURE

Tap **Play** to start Timed Burp Cycle.

Timer status will be displayed. Play will change to **Stop**.

If you want to manually start a Burp Cycle tap the **Pump Icon**.

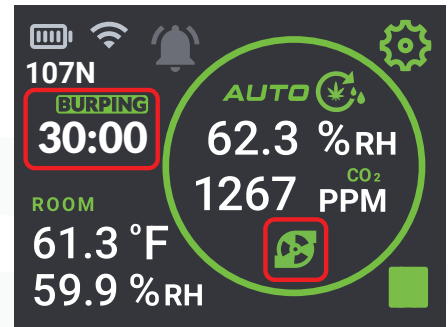
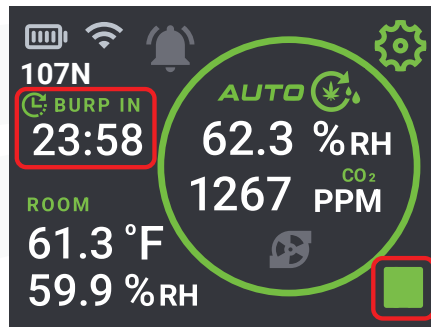
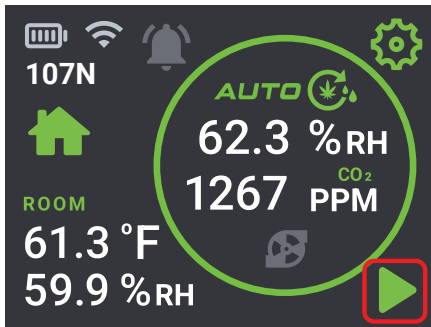

The CurePuck is now in a Timed Burp cycle with AutoCure on, it will aim to maintain the setpoint plus burp on the timed cycle.

The Alarm Icon will flash RED if Room Relative Humidity, Container Relative Humidity or Room Temperature exceeds the programmed values.

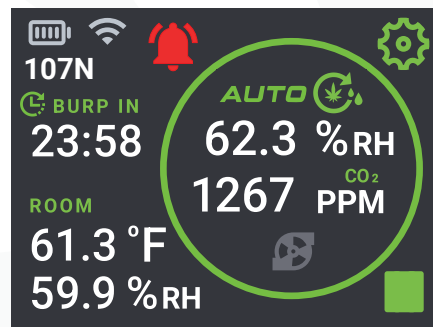

Note that the Alarms set within the CurePuck itself will NOT notify you by email, push notifications or text message unless you first set it up in the web dashboard and tell it where to send the email or text and their frequency.

To setup Alarms to notify you need to set it up using the web dashboard using a web browser on your computer.

<https://dashboard.curepuck.io/>

Explaining Vapor Pressure Deficit - VPD: The Plant's Breathing Process

Alright, picture a plant, it's sweating all the time. Just like people, plants give off water, but instead of calling it sweating, the process of the water leaving the plant is called transpiration. Water moves from the roots, up through the plant, and out through tiny pores in the leaves called stomata. The moment that water reaches the surface of the leaf, it needs to evaporate so that more water can move up from the roots.

This movement of water through the plant brings along nutrients for the plant to grow and thrive. If the evaporation is too slow we have poor growth, if the evaporation is too quick the leaves dry out. We need to control the rate of evaporation from the leaves for optimal growth.

What Controls Evaporation?

Evaporation happens fast or slow depending on the combination of two things:

1. **Temperature** – Warm air speeds up evaporation, cool air slows it down.
2. **Humidity** – Dry air speeds up evaporation, while humid air slows it down.

These two factors **together** decide how **quickly water can leave the leaf**.

For example

25°C day (77°F) at a relative humidity (RH) of 50% will give us a VPD of 1.59 kPa. We can get the same VPD value with these combinations. Thus, we get the same transpiration rate from the plant at all these combination of values. Larger VPD number means drier air.

23°C → 43.4% RH

21°C → 36.1% RH

19°C → 27.6% RH

17°C → 17.9% RH

15°C → 7.2% RH

We refer to the combination of **temperature** and **humidity** as **VPD—Vapor Pressure Deficit**. A more in depth explanation of VPD can be found in **Appendix A** (pages 34-41).

Curing - The Difference Between a Growing Plant and a Cut Plant

In **Section 1**, we talked about how a living plant **moves water up from its roots** and releases it through the leaves. This constant water movement is called **transpiration**, and it only works because the plant is still alive.

But once a plant is **cut**, the game changes. The plant **can't pull up any more water** from the roots. Now, we are drying. Drying is only about **how fast water leaves the plant**, and that is still controlled by **VPD** - the combination of temperature and humidity.

Curing vs Drying

- **Drying** is just removing moisture from the plant.
- **Curing** is a **controlled** drying process that preserves **flavor, aroma**, and **texture**.

By keeping VPD controlled, we allow the plant's moisture to escape **predictably and evenly**, preventing harshness and mold while maintaining **smoothness** and **potency**.

Final Takeaway: Curing is Controlled Drying

- A **living plant** replaces lost water from the roots.
- A **cut plant** has no water supply - water only moves outward.
- **Too fast = Uneven moisture inside vs outside of bud, Over-dry leaves, poor quality**
- **Too slow = Mold risk if %RH gets too high**
- **The right VPD = Perfect cure & consistent quality**

Using VPD is the best way we currently know of to produce consistent, reliable quality results.

There are some limits we have to stay within to prevent mold from ruining your product.

FunkGuard is the solution. While using VPD mode in AutoCure your Curepuck constantly monitors the relative humidity (%RH) to ensure that it never gets above 60%RH where mold may start to become a risk. If the container ever gets too humid CurePuck automatically pumps air in, bringing the %RH back down to acceptable levels, see **Appendix A** (pages 34-41) for details.

CurePuck App - Android Installation and Device Provisioning Instructions

Notes:

The screenshots below may vary between different versions of Android operating systems however the general intent is the same. Note: End user spam filters will sometimes block the signup emails, in enterprise environments this can even happen up-stream of your junk box due to your company's mail server filter settings. If this happens test on a personal email, like a gmail. Then have your IT department whitelist noreply@curepuck.io.

After setting up your first CurePuck, save your Wi-Fi credentials in the CurePuck App. These credentials can be transferred to additional CurePucks.

Routers vary greatly as to the number of wireless devices that can be connected. Ensure your router has enough capacity for your CurePucks. Most wireless routers can handle at least 20 connections and some can connect up to 250 devices. **See page 28 for a list of routers.**

On your Smart Phone

Tap **Google Play**

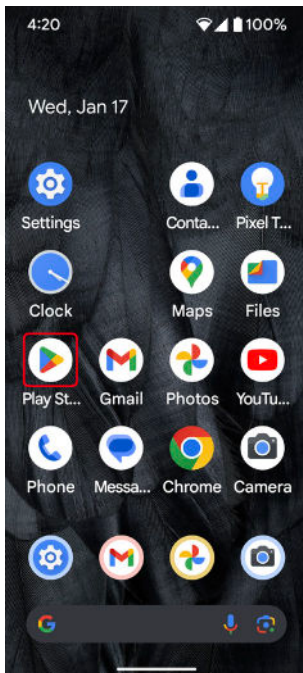

Search **Cure Puck**

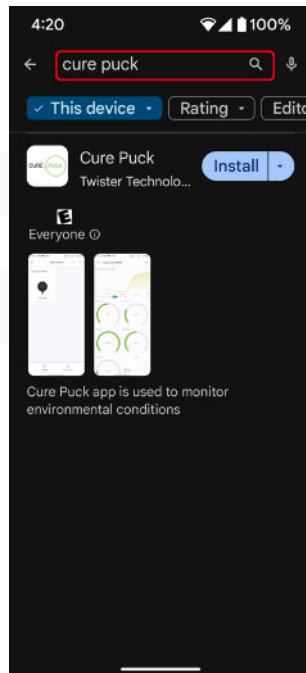

Tap **Install**

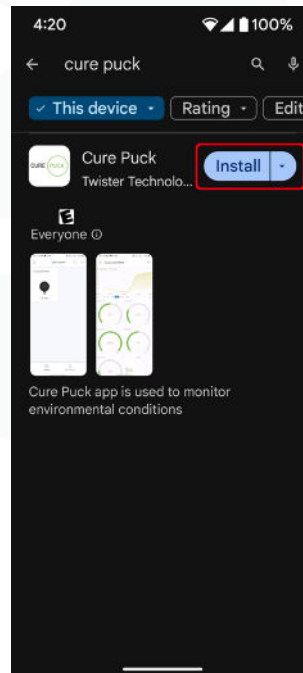

Tap **Open**

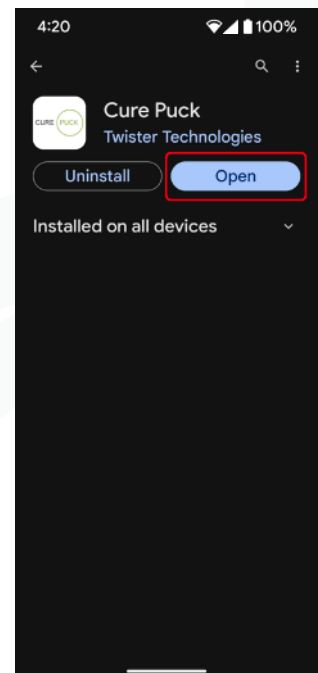

ANDROID INSTALLATION

Tap Sign Up



Enter Email

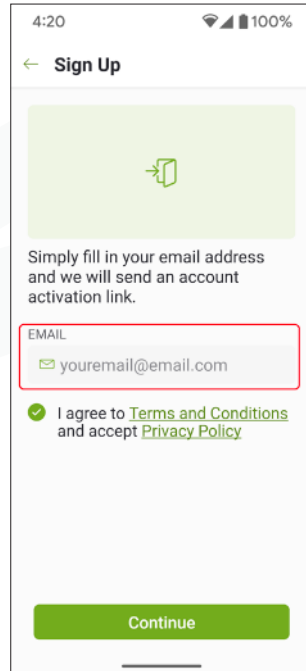

Read and Accept Terms

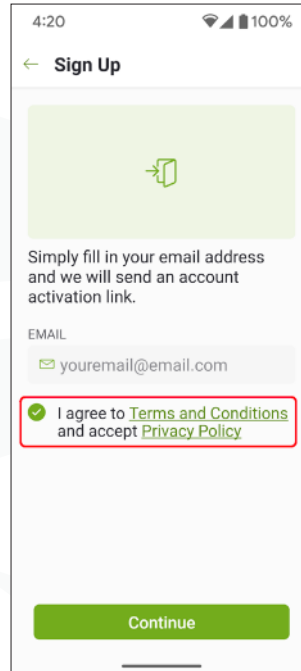

Tap Continue

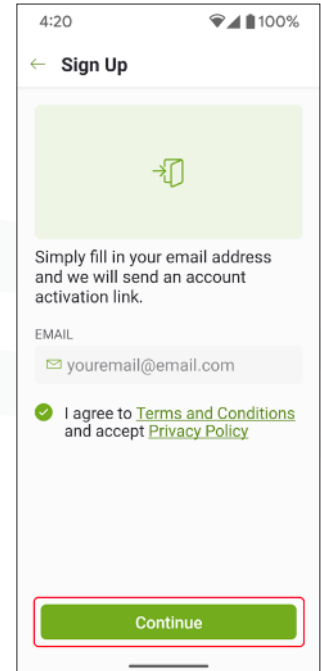

Tap Check Inbox

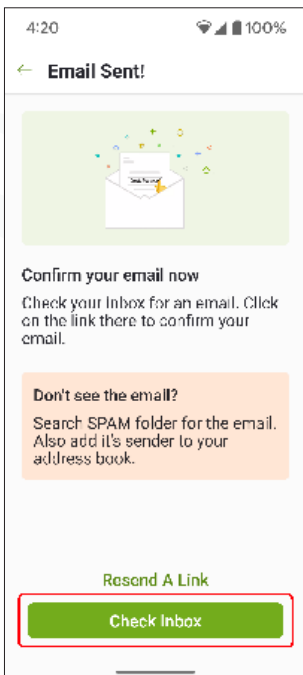

Check Email

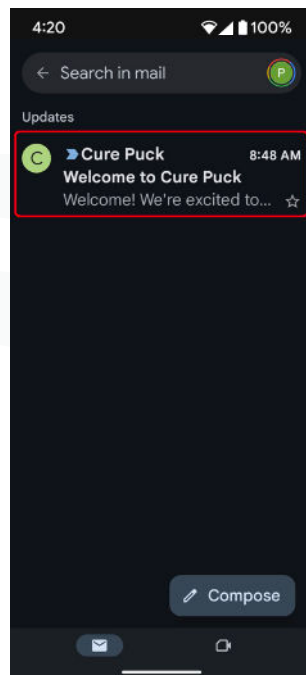

Tap Create Password

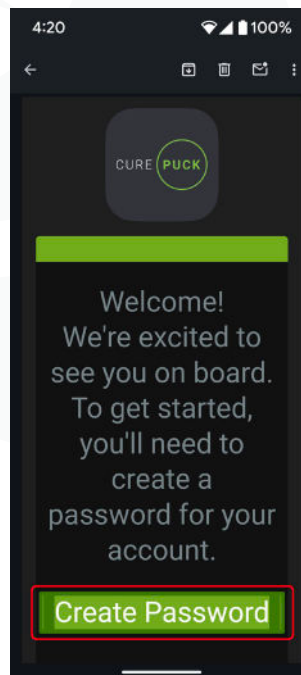

Enter Password

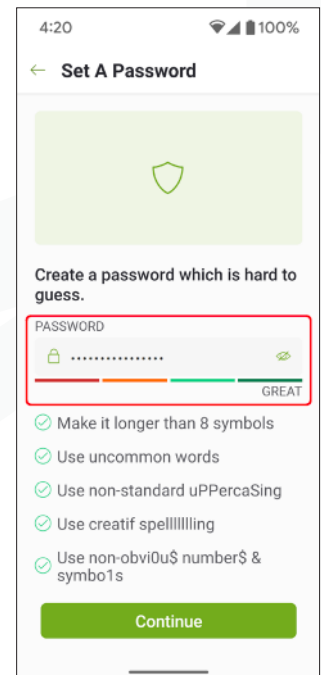

ANDROID INSTALLATION

Tap **Continue**

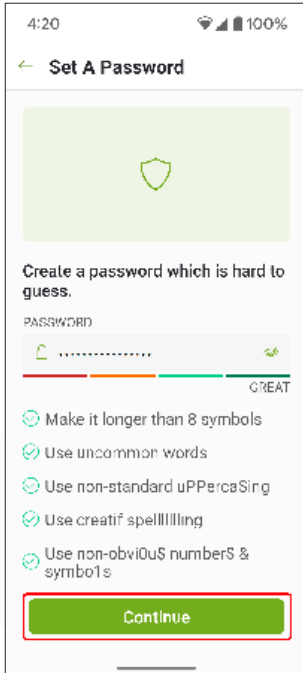

Enter **Organization Name**

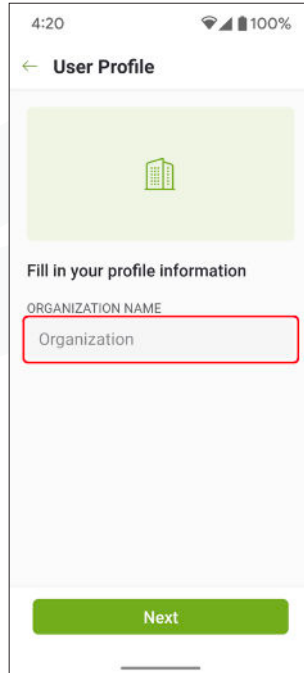

Tap **Next**

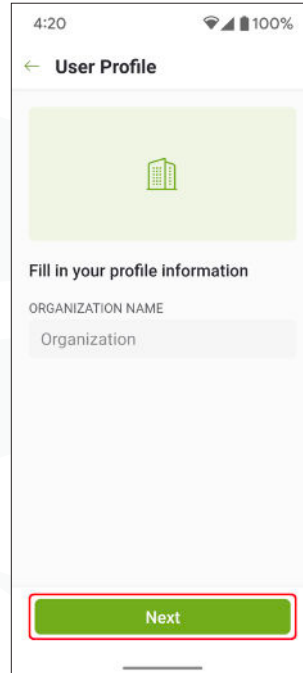

Tap **+ Add New Device**

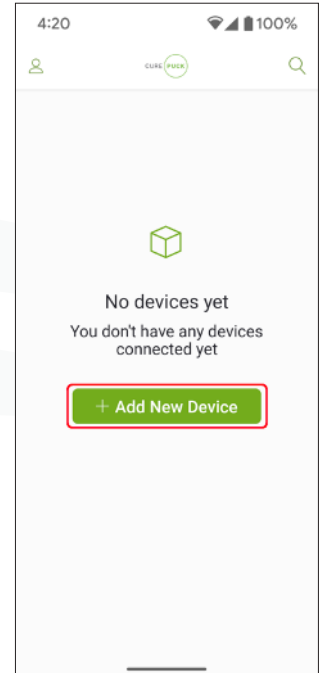

On your Cure Puck

Use of Wi-Fi Provisioning Mode will disconnect the Cure Puck from any existing Network Connections and Cure App Connections. Your device will no longer be visible and a loss of data will occur. If your CurePuck is not connecting to your network, turn it off for 5 seconds and turn it back on. The CurePuck will use existing settings and attempt to reconnect to your network.

Tap **Settings**

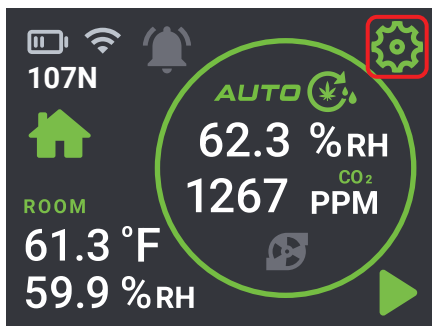

Tap **Network**

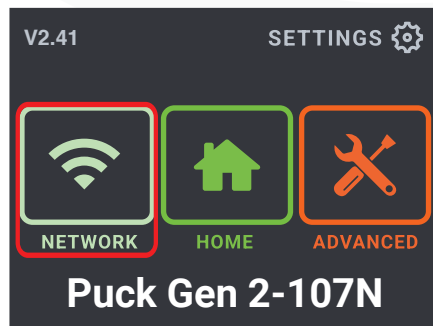

Tap **Provision Mode**

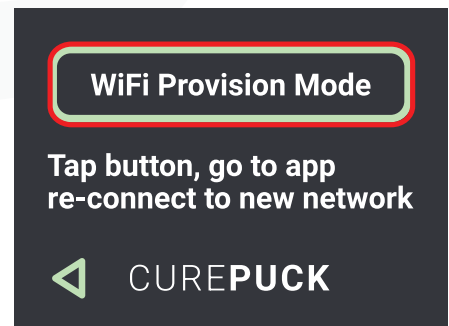

ANDROID INSTALLATION

Back to your Smart Phone

Tap **Start**

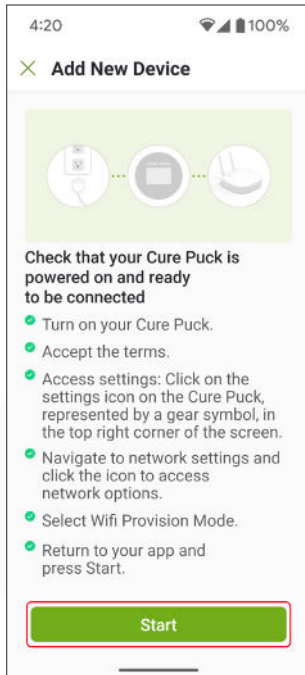

Tap **Continue**

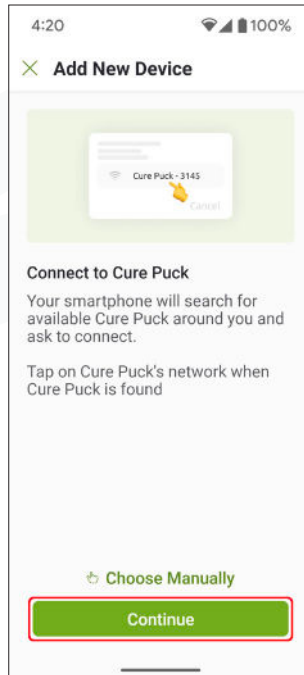

or

Tap **Ready**

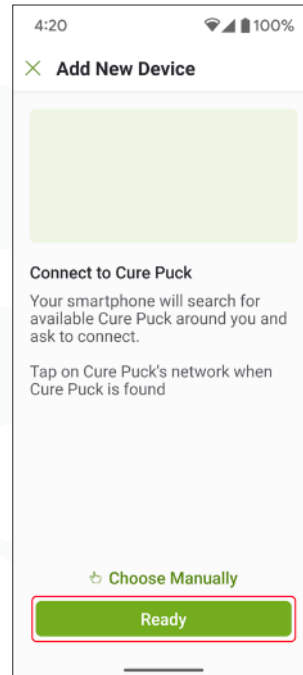

Connect to device

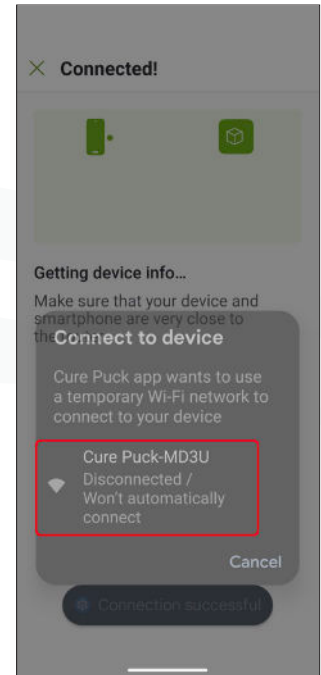

Tap **Continue**

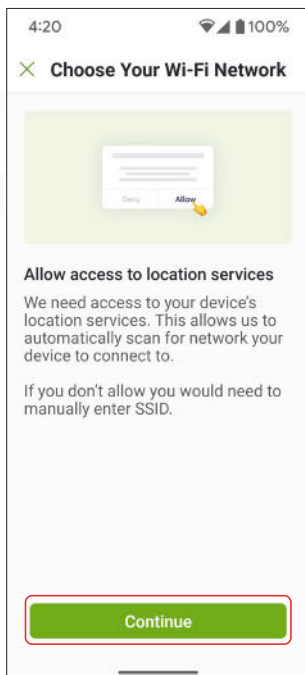

Tap **Only This Time**

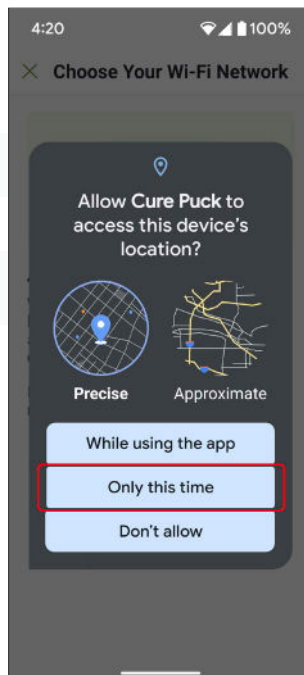

Tap **Network**



Confirm Network

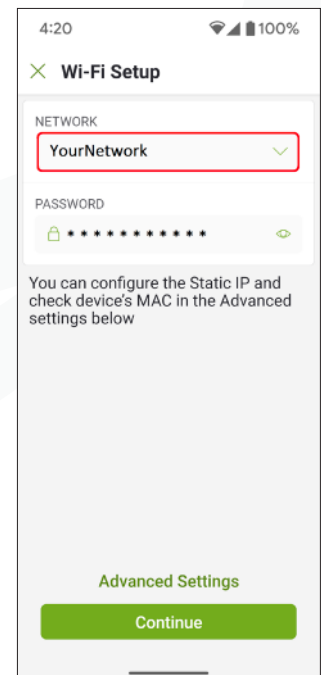

NOTE

Access to Location Identifier is an Android safety protocol. More can be learned here

<https://developer.android.com/about/versions/marshmallow/android-6.0-changes#behavior-hardware-id>

ANDROID INSTALLATION

Enter Password

4:20 100%

Wi-Fi Setup

NETWORK
YourNetwork

PASSWORD
••••••••

You can configure the Static IP and check device's MAC in the Advanced settings below

Advanced Settings

Continue

Tap Continue

4:20 100%

Wi-Fi Setup

NETWORK
YourNetwork

PASSWORD
••••••••

You can configure the Static IP and check device's MAC in the Advanced settings below

Advanced Settings

Continue

Wait for it!!

4:20 100%

Configuring Device

Configuring device

Reconnecting back to cloud

Waiting for device online

Cancel

Tap Finish

4:20 100%

Device Connected

Cure Puck MD3U connected!

Cure Puck MD3U

+ Add New Device

Finish

Remember you can also access the **Web Portal** at <https://dashboard.curepuck.io/> using the same login.

IPHONE INSTALLATION

CurePuck App - iPhone Installation and Device Provisioning Instructions

Notes:

The screenshots below may vary between different versions of iPhone operating systems however the general intent is the same.

After setting up your first CurePuck, save your Wi-Fi credentials in the CurePuck App. These credentials can be transferred to additional CurePucks.

Routers vary greatly as to the number of wireless devices that can be connected. Ensure your router has enough capacity for your CurePucks. Most wireless routers can handle at least 20 connections and some can connect up to 250 devices. **See page 28 for a list of routers.**

On your Smart Phone

Tap **App Store**

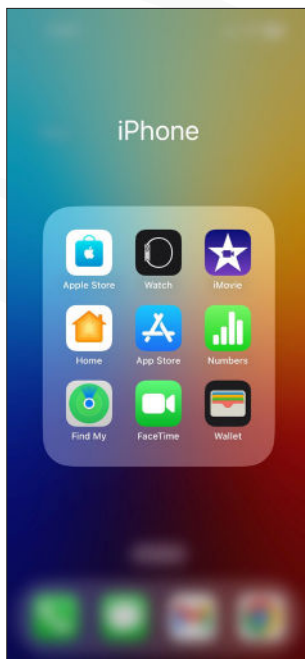

Search **Cure Puck**



Tap **Download Icon**



Tap **Open**

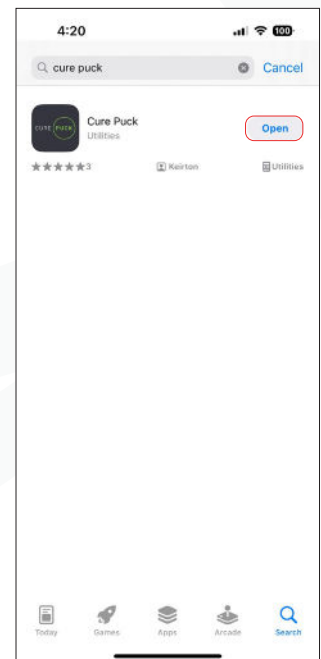

IPHONE INSTALLATION

Tap Sign Up



Enter Email

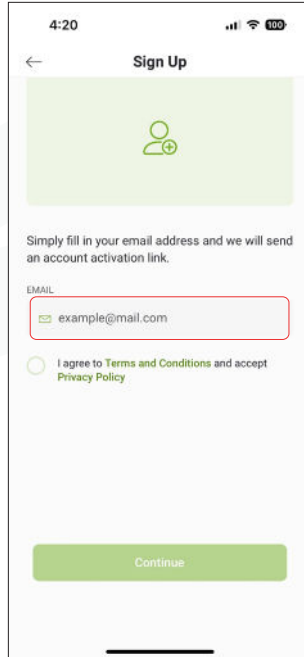

Read and Accept Terms

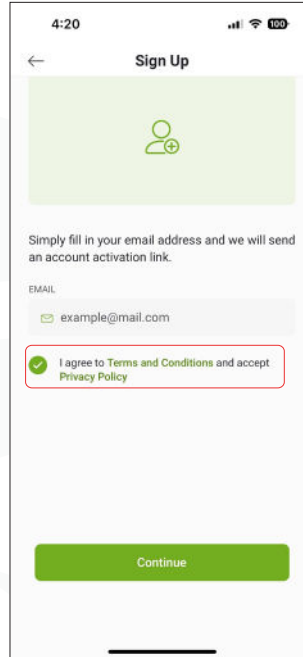

Tap Continue

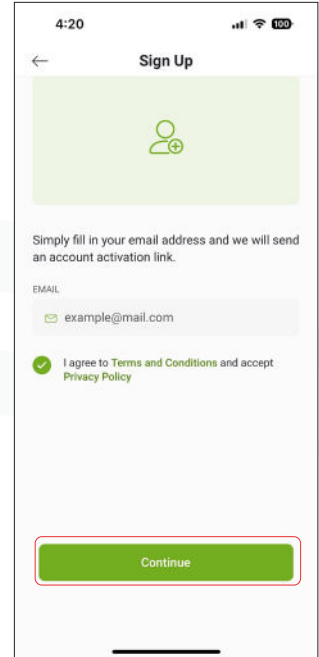

Tap Open Inbox

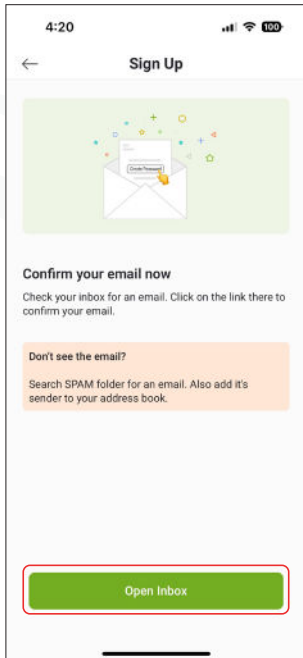

Check Email

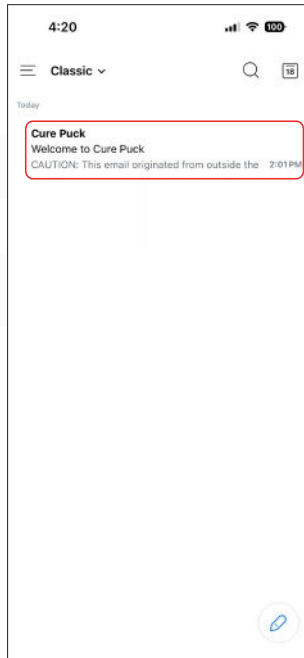

Tap Create Password

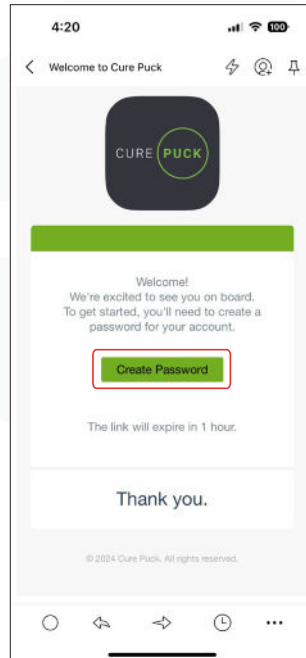

Enter Password

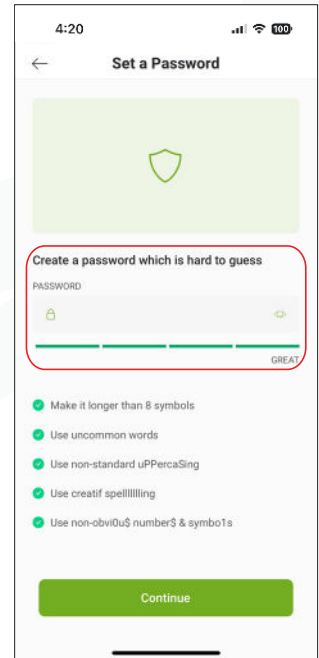

IPHONE INSTALLATION

Tap **Continue**

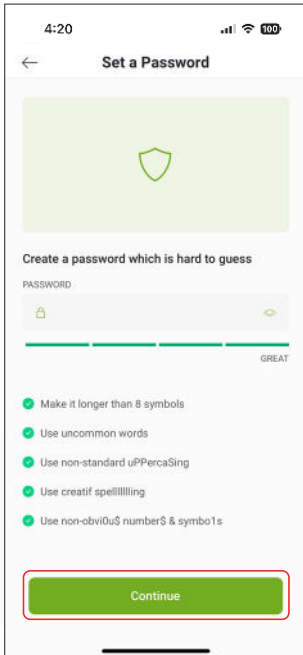

Enter **Organization Name**

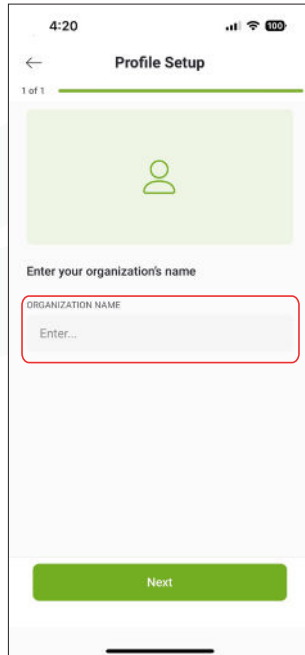

Tap **Next**

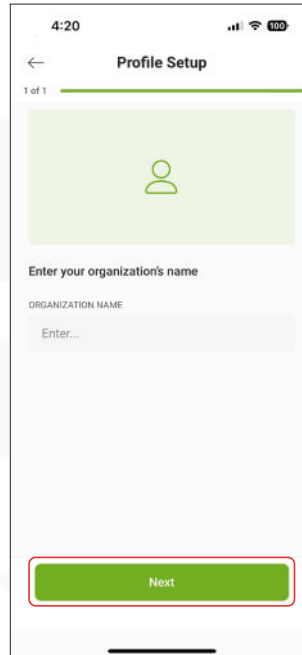

Tap **+ Add Device**

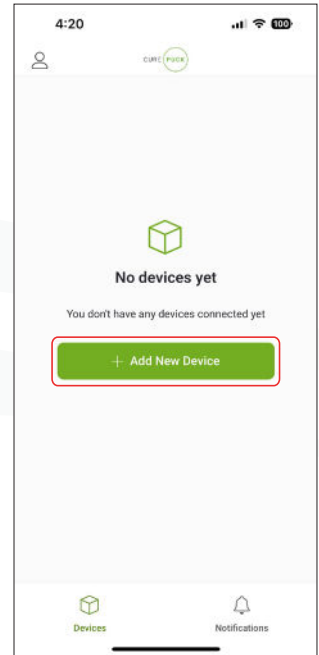

On your Cure Puck

Use of Wi-Fi Provisioning Mode will disconnect the Cure Puck from any existing Network Connections and Cure App Connections. Your device will no longer be visible and a loss of data will occur. If your Cure Puck is not connecting to your network, turn it off for 5 seconds and turn it back on. The Cure Puck will use existing settings and attempt to reconnect to your network.

Tap **Settings**

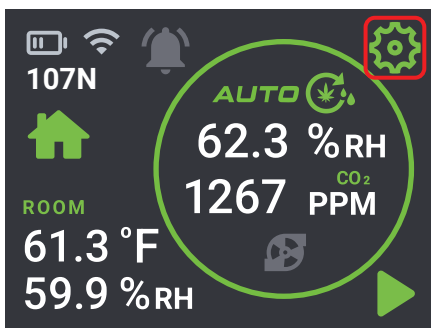

Tap **Network**

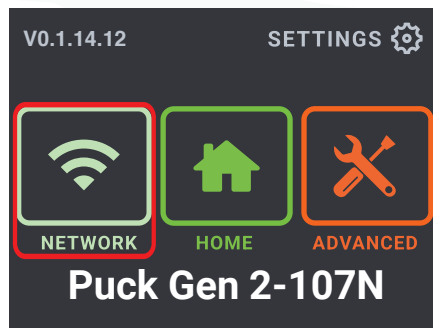

Tap **Provision Mode**

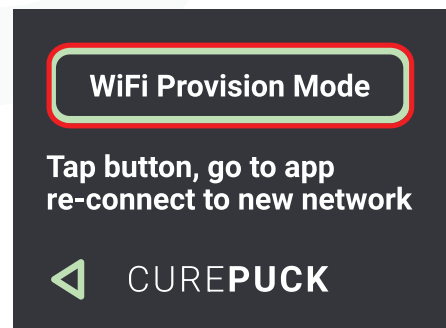

IPHONE INSTALLATION

Back to your Smart Phone

Tap **Start**

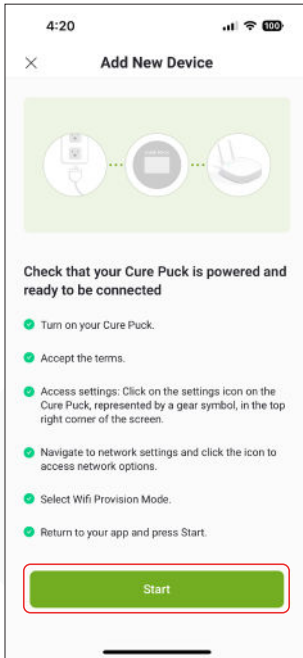

Tap **Don't Allow**

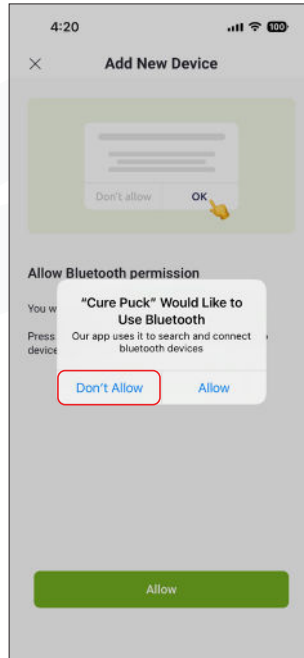

Tap **Allow**

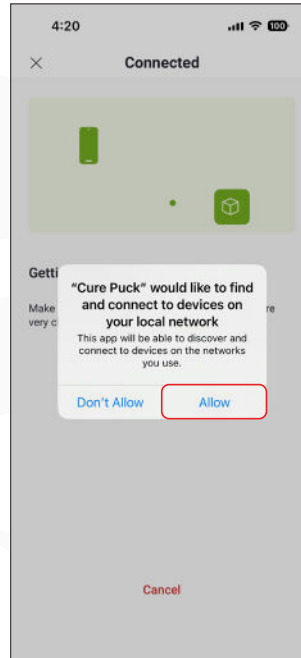

Tap **Continue**

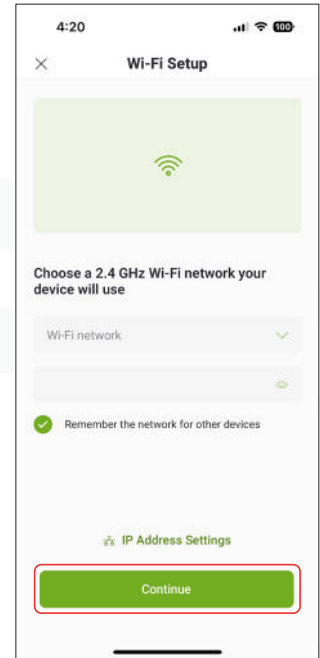

Wait for it!!

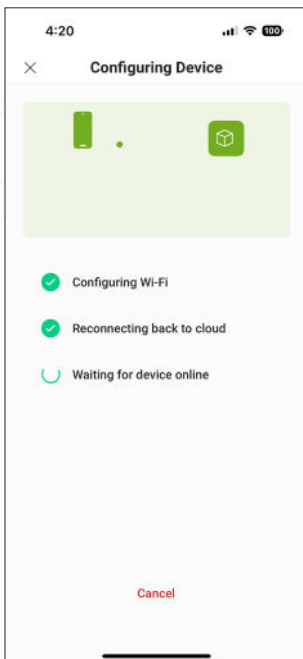

Tap **Finish**

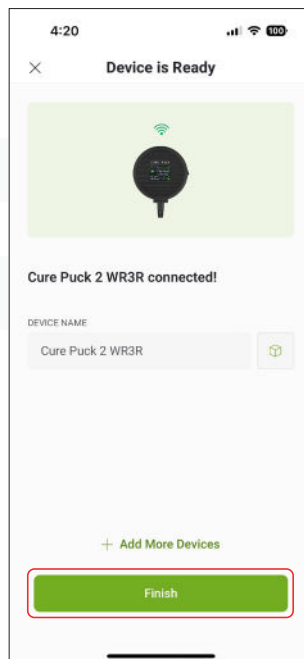

Remember you can also access the **Web Portal** at <https://dashboard.curepuck.io/> using the same login.

ROUTER SUGGESTION



We do not recommend nor have we tested any of these.

Here is a list of common routers.

1. TP-Link Archer C7 - Supports up to 50 wireless connections.
2. Netgear Nighthawk AC2300 (R7000P) - Supports up to 45 wireless connections.
3. Linksys EA7500 - Supports up to 50 wireless connections.
4. Asus RT-AC68U - Supports up to 50 wireless connections.
5. D-Link DIR-882 - Supports up to 50 wireless connections.
6. Netgear Orbi RBK50 - Supports up to 40 wireless connections per unit.
7. Google Nest WiFi - Supports up to 100 wireless connections.
8. TP-Link Deco M5 - Supports up to 100 wireless connections.
9. Ubiquiti AmpliFi HD - Supports up to 100 wireless connections.
10. Linksys Velop Tri-Band - Supports up to 100 wireless connections.

Here is a list of high density routers.

1. Cisco Meraki MR42 - Designed for high-density environments, supports up to 250+ wireless connections.
2. Ubiquiti UniFi UAP-AC-HD - Supports up to 500 clients per radio, suitable for handling around 250 wireless connections.
3. Aruba Instant On AP22 - Supports up to 256 wireless clients.
4. Ruckus R510 - Supports up to 512 concurrent clients, suitable for handling around 250 wireless connections.
5. Cambium Networks cnPilot e700 - Supports up to 256 connected clients.

MANUAL BURP CONTROL

The Pump Icon activates a burp cycle for the duration of the setting in Air Exchange Duration. If you activate a manual burp cycle this will not change any other settings or timers. A manual burp will be activated in addition to the Air Exchange Frequency Timer.

If a burp is activated manually the pump icon highlights Green, tapping it again will stop the burp cycle.

Tap **Pump Icon** to **activate** Burp Cycle

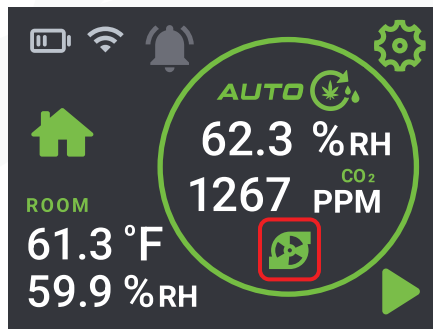

Tap **Pump Icon** to **stop** Burp Cycle

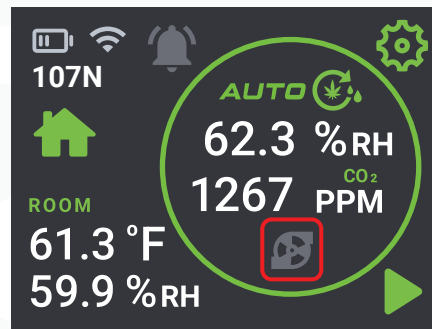

NOTIFICATIONS

Your CurePuck will display the Alert Icon Red when an Alert is activated.

Tap **Alert Icon**

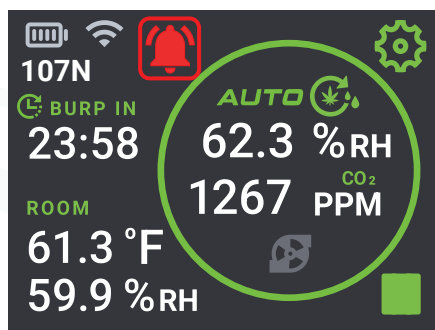

Notifications Listed

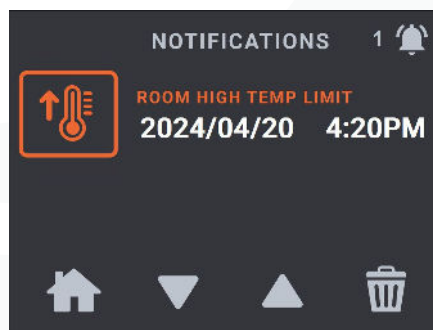

Tap to **Delete Notification**

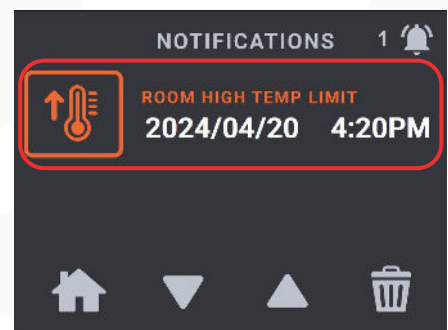

Tap **Trash Icon** to **Delete All Notifications**

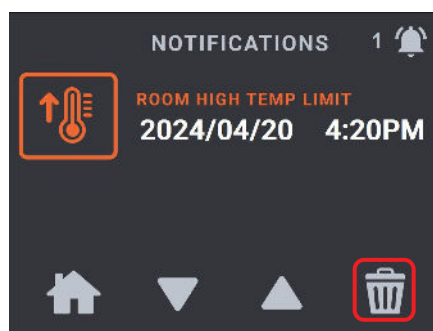

MORE SETTINGS

The CurePuck has 4 Alerts.

For your CurePuck to send Alerts to your Phone and/or Email the alert must be ON. This applies to each alert individually. We recommend setting all alerts to ON.

Notifications can be stopped by the phone, in the settings page in the App. SMS and Email notifications must be setup on the web dashboard.

Tap **Settings**

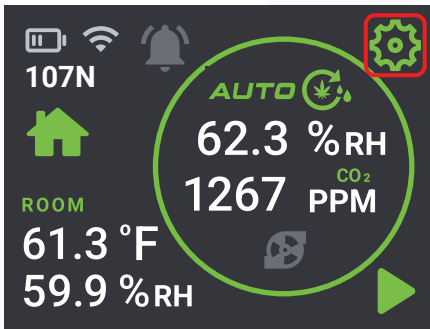

Room High Temp Alert

Tap **Advance**

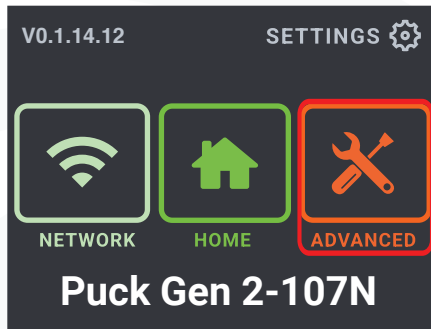

Room High RH Alert

Tap **Next**

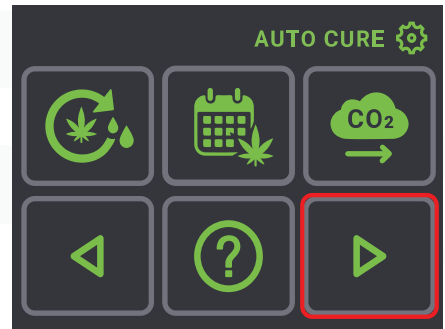

Flower too Wet Alert



Is activated when the temperature in the room exceeds the set point and the alert is turned ON.



Is activated when the RH in the room exceeds the set point and the alert is turned ON.



Is activated when the RH in the container exceeds the set point and the alert is turned ON.

Room Low RH Alert

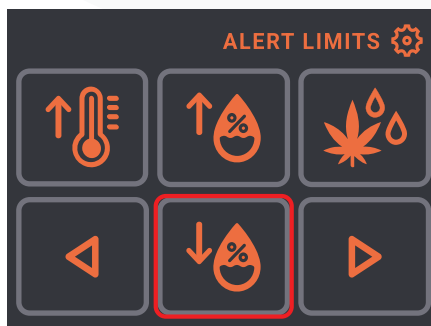

Is activated when the RH in the room falls below the set point and the alert is turned ON.

NOTE

- See **Using your App** for more details about configuring your App.
- For Connecting your Cure Puck to Android App see Pg 12.
- For Connecting your Cure Puck to Iphone App see Pg 17.

RECONFIGURE vs WIFI PROVISION MODE

The **Reconfigure** option provides a secure way to update the Cure Puck's Wi-Fi password without using the **WiFi Provision Mode** button on the device's touchscreen (see pages 21–23 for Android and 26–27 for iPhone). **WiFi Provision Mode** is intended only for setting up a new Cure Puck that is being connected to the internet for the first time. Using **WiFi Provision Mode** on an already configured device will delete all previously stored data and create a new instance of the puck.

In contrast, **Reconfigure** is recommended when the user only needs to update the network password, as it avoids restarting the device and generating a new instance that may leave the previous one inactive.

When **Reconfigure** is used, the historical information remains intact and new data is added to the existing record. If **WiFi Provision Mode** is used instead, the previous instance becomes permanently disconnected, and the new instance starts without carrying any historical data forward.

Follow the steps below to **reconfigure** your device's internet connection.

On your Smart Phone

Select the **Cure Puck**

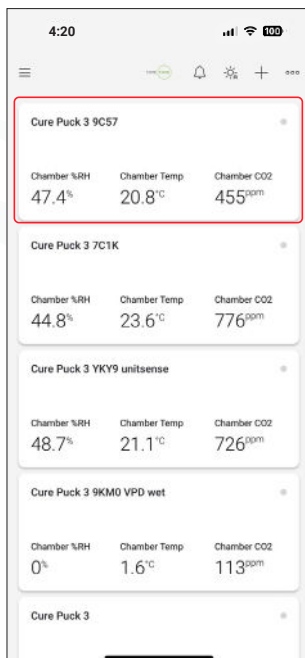

Tap **Information Icon**

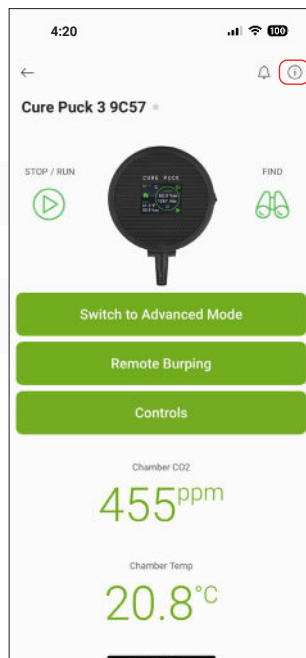

Tap **More Options Icon**

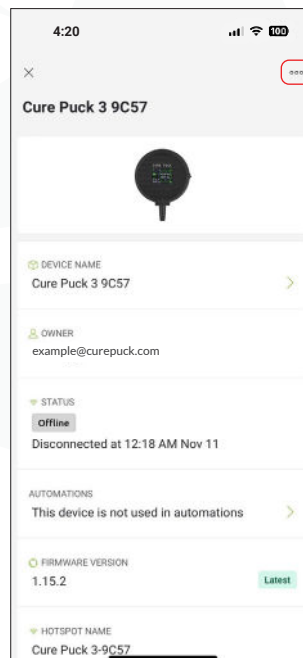

Tap **Reconfigure**

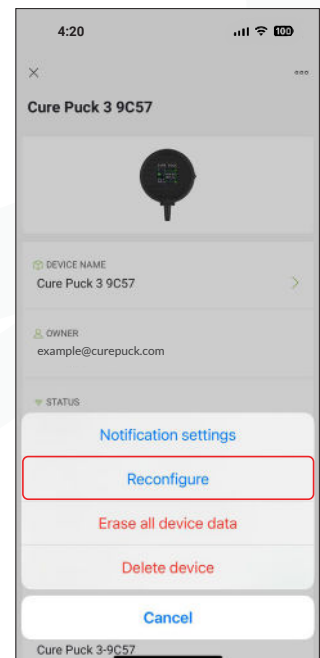

MORE SETTINGS

Tap Start

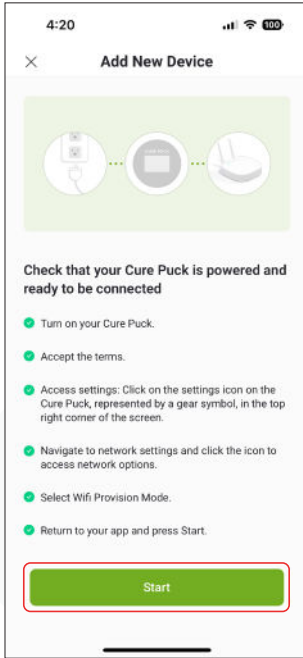

Tap Don't Allow

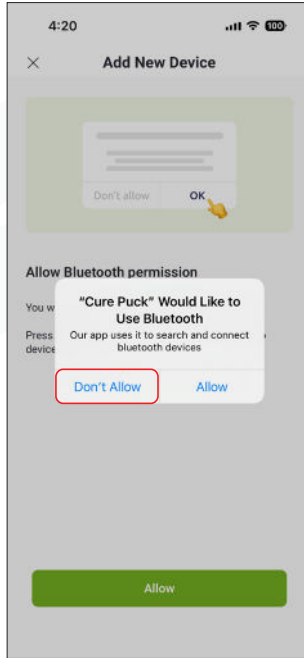

Tap Allow

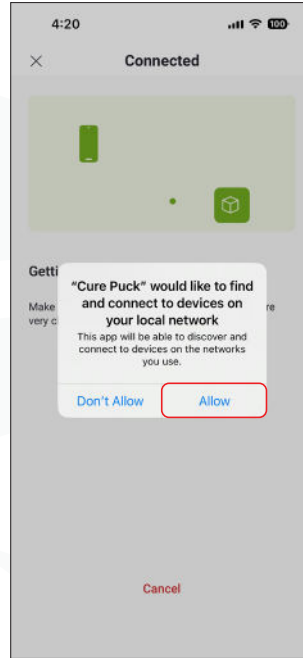

Tap Continue

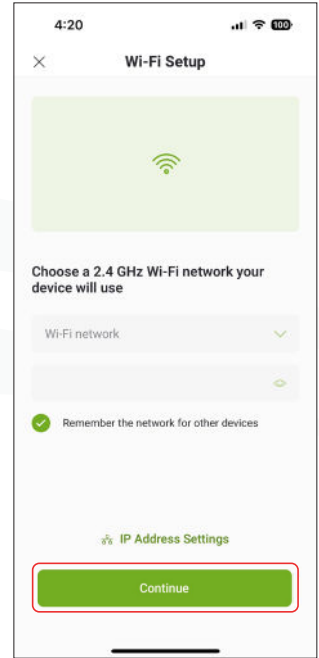

Wait for it!!

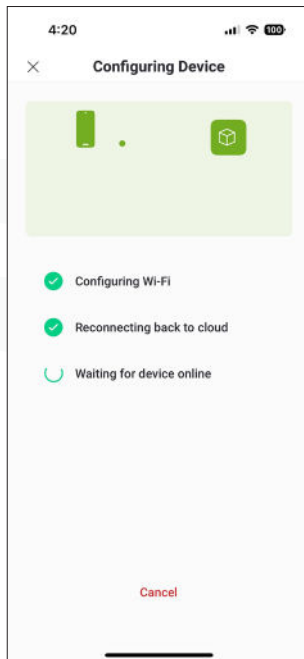

Tap Finish

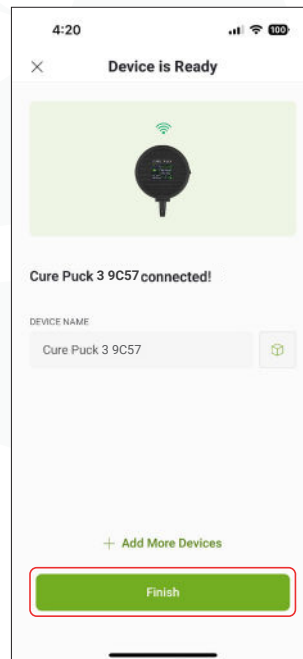

RESET TO FACTORY SETTINGS

The **Reset to Factory Settings** option restores the device to its original factory configuration. This process removes all saved preferences, WiFi settings, custom parameters, and any data stored during operation.

Please note that this action is permanent and cannot be undone. Make sure to back up any important information before proceeding.

Remember that, in accordance with Cure Puck policy, the device is designed to assist the curing process and is not responsible for improper use that may affect the final product.

Follow the steps below to reset the Cure Puck to factory settings.

Tap **Settings**

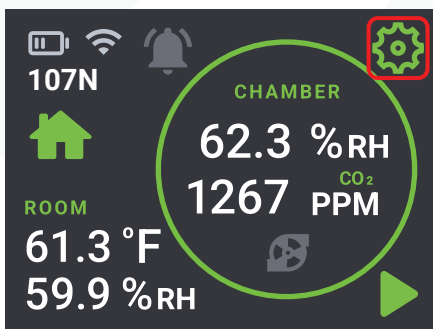

Tap **Advance**

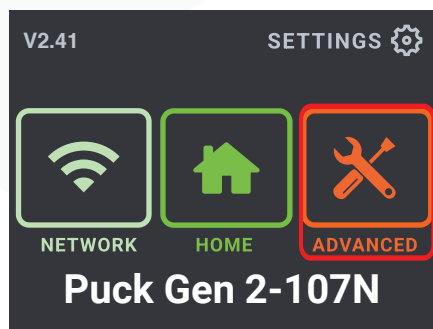

Tap **Help**

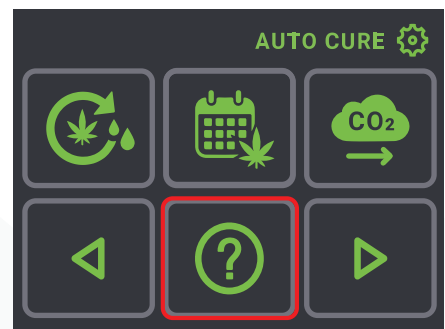

Tap **Reset to factory settings**

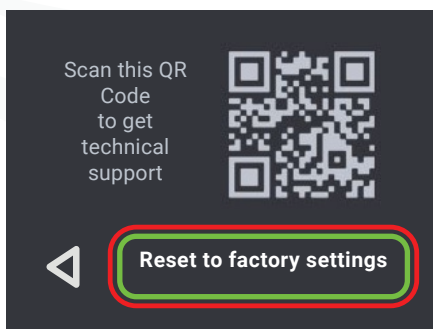

Tap **Yes**



Tap **I Agree**

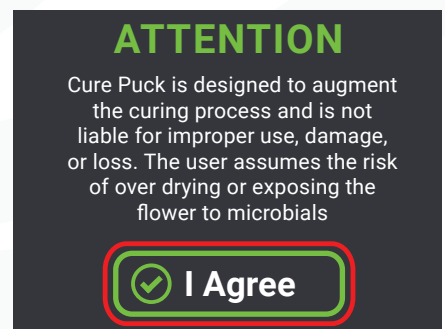

WHAT IS RELATIVE HUMIDITY %RH

Understanding Vapor Pressure

First, to understand %RH, we need to understand vapor pressure.

Vapor pressure is the partial pressure of water vapor in the air at a given temperature, and the partial pressure of a gas is a direct measure of the quantity of molecules present in the mixture for a given temperature and volume. In our case, the partial pressure of water vapor directly measures how many water molecules are present compared to all the other gases.

If you removed nitrogen, oxygen, and every other gas from a sealed container of air and kept only the water vapor, the pressure measured once it expanded to fill the remaining space would define its partial pressure.

As water molecules escape from a liquid surface into the gas phase, they exert a pressure this is the vapor pressure. The warmer the system, the more kinetic energy the water molecules have, making it easier for them to evaporate, and the higher the vapor pressure becomes.

Saturation Vapor Pressure

When the air is fully saturated with water vapor at a specific temperature, the vapor pressure reaches the saturation vapor pressure for that temperature, the maximum possible before condensation begins. This concept is key to understanding relative humidity, as %RH is the ratio of actual vapor pressure to saturation vapor pressure.

In a sealed jar with liquid water and no leaks, evaporation will continue until the rate of evaporation equals the rate of condensation, at which point the vapor pressure equals the saturation vapor pressure for that temperature. If the jar is heated, the kinetic energy of the water molecules increases, evaporation accelerates, and the equilibrium shifts to a higher saturation vapor pressure.

At the saturation vapor pressure, %RH is always 100%. This means the air contains the maximum amount of water vapor it can be in equilibrium with at that temperature, and any additional water vapor would begin to condense.

Conditions for Maintaining Saturation

To maintain saturation vapor pressure in a sealed jar, there must be some liquid water present. If the jar is heated and all the liquid water has evaporated, the air may still contain water vapor and exert a measurable vapor pressure, but if more liquid water were available, additional evaporation could occur. In this case, the system is not at saturation, and the %RH is less than 100%.

%RH below 100% means the air is undersaturated, it contains less water vapor than it potentially could at that temperature. This is typical in open or partially sealed environments, or after heating a sealed jar without enough water left inside to reach the new, higher saturation vapor pressure.

Why %RH Matters

This is where the %RH measurement comes in. For example, at 60% RH, the air currently contains 60% of the maximum water vapor it could be in equilibrium with at that specific temperature before becoming saturated. In other words, the actual vapor pressure is 60% of the saturation vapor pressure. This is why it's called Relative Humidity it is relative to the maximum possible water vapor at a given temperature.

Since the saturation vapor pressure increases with temperature, the same %RH at two different temperatures does not represent the same amount of water vapor in the air. For example, 60% RH at 30°C contains significantly more water vapor than 60% RH at 15°C. To accurately define the environment, both the temperature and the %RH must be known, not just %RH alone.

WHAT IS VAPOR PRESSURE DEFICIT VPD(kPa)

To understand VPD (Vapor Pressure Deficit), it helps to build on the concepts of Vapor Pressure and Relative Humidity (%RH). As explained earlier:

- **Vapor Pressure** is the partial pressure of water vapor in the air, and
- **Saturation Vapor Pressure** is the maximum water vapor pressure possible at a given temperature before condensation occurs.

VPD is the difference between the saturation vapor pressure and the actual vapor pressure in the air. In simple terms, it measures how much more water vapor the air can absorb before becoming saturated.

VPD is important because it's a direct indicator of drying power, how strongly the environment will pull moisture from surfaces, including plant leaves or curing materials. While **%RH** tells us how "full" the air is with moisture, **VPD** tells us how far it is from full.

- **A high VPD** means the air is relatively dry and capable of absorbing more moisture, increasing evaporation or transpiration.
- **A low VPD** means the air is close to saturation, so evaporation slows down.

VPD = saturation vapor pressure – actual vapor pressure

Since both vapor pressures depend on temperature, and the actual vapor pressure also depends on %RH, VPD automatically accounts for both factors at once. This makes it a more precise measure of drying power than %RH alone.

For example, two environments might both measure 60% RH, but if one is at 30°C and the other at 15°C, their VPDs will be very different. At 30°C, the saturation vapor pressure is much higher, so the gap between actual and saturation vapor pressure is larger resulting in stronger moisture pull or drying power even though the %RH reading is the same.

PUTTING IT ALL TOGETHER VPD AUTOCURE

Why VPD Has a Major Advantage Over %RH

One of the key advantages of using VPD over %RH is that equal VPD values at different temperatures represent the same drying power.

What VPD Measures

VPD quantifies the difference between:

- How much moisture the air could hold (saturation vapor pressure) and
- How much it currently holds (actual vapor pressure).

This gap directly drives evaporation or transpiration - in other words, how strongly the air “pulls” moisture from a surface.

When VPD is the same, that drying force is the same, regardless of the air temperature.

Same VPD, Same Drying Force

For example, both 20°C and 30°C at a VPD of 1.0 kPa exert the same drying force, even though the air at 30°C holds more moisture.

This is because VPD measures the gap between saturation and actual vapor pressure, not the total amount of moisture in the air.

- At 20°C, saturation vapor pressure is about 2.34 kPa, so 1.0 kPa VPD corresponds to ~57% RH.
- At 30°C, saturation vapor pressure is about 4.24 kPa, so 1.0 kPa VPD corresponds to ~76% RH.

Despite the different RH values, the moisture pull is the same - illustrating how VPD provides a temperature-adjusted view of drying power, making it a more consistent metric for environmental control.

Curing Caveat: %RH Must Stay Below Safe Levels

Too high of an %RH can result in mold or a funky smell.

This is important when selecting the correct VPD setting, you need to understand what your maximum expected room temperature will be.

AutoCure Behavior

With AutoCure a target setpoint is selected. This target needs to be selected based on your given room temperature control range; the problem arises when your room temperature rises above the expected upper limit.

VPD at Unexpected High Temperatures

From the example:

If VPD is set to 1.0kPa for an intended finish target of 57% RH at 20°C, everything is great until say your HVAC system in your room breaks down and the temperature rises way above the limit.

With pure VPD control alone:

The controller would maintain the 1.0kPa VPD set point which would result in the chamber rising to 76% RH. Although the VPD was maintained, in the context of curing a %RH of 76% would be very dangerous for mold growth if it stayed there for any duration beyond a few hours.

This is where FunkGuard kicks in. **FunkGuard** will detect this dangerous condition and put a ceiling on the %RH of 60%, it will dump the excess moisture.

You don't want your room temperature to go out of control so that FunkGuard has to kick in but as an emergency or due to incorrect VPD settings for the expected temperature, FunkGuard will save your flower until you get the room temperature back under control.

Consequences of Emergency Moisture Dumping

The problem with this is it had to dump out excess moisture so when you bring the temperature back down, it may not be able to hit the desired %RH target since it has lost too much moisture in the emergency venting so it may cause the flower to be over dried if near the end of the cure.

This is much better than mold forming, the flower will still be good, just not ideal. This is why temperature of the room is important to control.

Closer Look at What's Happening:

If your target is 58% RH at 20°C:

- This corresponds approximately to ~0.98 kPa VPD.
- This is safe as long as the room doesn't get too warm.

If the room reaches 21.5°C:

- The same 0.98 kPa VPD -> 60% RH (upper safety limit).
- Any temperature higher than this pushes RH above 60% triggering FunkGuard to dump moisture to prevent mold.

This is why your **VPD** setpoint must be chosen based on the **maximum** room temperature you expect and why room temperature control is required for the ideal cure.

If you expect your room might reach 24°C, for example, to stay at or below 60% RH in a 24°C room, you should set your VPD to at least 1.19 kPa.

RELATIVE HUMIDITY AUTO CURE MODE

How %RH Control Actually Works

%RH control works by maintaining a fixed relative humidity inside the chamber, regardless of changes in temperature.

When room temperature is tightly regulated within a very narrow range this method can be effective since the relationship between temperature and the air's moisture-holding capacity stays relatively constant.

When Temperature Is Stable

In stable temperature environments, holding a constant %RH can work fine, however, %RH control assumes tight temperature stability, and even small fluctuations can shift the actual drying power significantly. That is where problems can begin if temperature is not tightly controlled.

What Happens With Temperature Swings

When using %RH control alone, the system will try to hold a constant RH say 58% regardless of temperature changes. This can lead to unintended moisture loss during temperature swings.

Example:

At 20°C, maintaining 58% RH means the air holds about 1.36 kPa of water vapor.

If the room temperature rises to 24°C, the air can now hold more moisture, so to maintain the same 58% RH, moisture from the flower would evaporate into the chamber head space - rising to a vapor pressure of 1.73 kPa.

When the Temperature Drops Again

Now, when the room cools back down to 20°C, that same 1.73 kPa of water vapor is still in the chamber air. But at 20°C, that vapor pressure now equals 74% RH well above the 58% target.

To correct this, the system vents moisture from the headspace to bring the RH back down.

The Real Problem

The moisture that was pulled from the flower during the warm period is now dumped which repeats every low -> high -> low temperature fluctuation.

This results in a net loss of internal moisture from within the trichomes that cannot be recovered. Since trichome resin is non-water-soluble, moisture pulled from inside cannot be reabsorbed later, leading to a permanent loss of stickiness, aroma, and quality.

%RH vs VPD AUTOCURE CONCLUSIONS

%RH Control

%RH control works well if you have very stable temperature control. It's simple to set up and easy to understand, since you're working directly with your desired %RH setpoint.

VPD control

On the other hand, maintains consistent drying power across temperature fluctuations.

However, there's an important consideration:

It's important to select a VPD setpoint that keeps RH below 60%, or FunkGuard will automatically intervene temporarily switching to %RH control to enforce a ceiling and prevent mold risk but in the process, it will need to dump excess moisture which can't be recovered later.

Choosing the Right VPD Setpoint

VPD control is a more advanced method of curing control but it required careful selection of the setpoint value based on your expected room temperature range.

Once the correct setting is selecte:

- It creates a temperature-tolerant control envelope
- It helps maintain consistent drying power
- And delivers a more uniform, higher-quality finished product

ROOM CONDITIONS

How the CurePuck Actually Removes Moisture

The CurePuck system removes moisture from the chamber by exchanging air with the surrounding room, it does not contain an internal dehumidifier.

What This Means

This means it can only reduce humidity inside the chamber if the room air is drier than the chamber air. If the room's relative humidity is equal to or higher than the target finish %RH, the system has no way to remove moisture from the chamber.

Room Requirements for Proper Curing

To ensure proper curing, your room environment must consistently remain below your target finish %RH. For most applications, the ideal room RH is below 55%, which gives the CurePuck enough drying headroom to reach common finish targets like 58%RH.

When the System Can't Pump

If the room RH is higher than the setpoint and the CurePuck needs to reduce moisture inside the chamber to bring the chamber conditions down to the setpoint, the CurePucks control algorithms simply will not pump, since doing so would further push the chamber RH away from the setpoint. This protects the cure, but it also means no fresh air exchange occurs, which is essential for a proper cure.

What Happens During High Room RH

Timed burps and CO₂-triggered burps will still happen if enabled, but AutoCure pumping will pause until the room conditions improve. In this state, curing slows down and can stall entirely if room RH remains too high which can cause conditions inside the chamber to rise uncontrollably above the setpoint and ruin the cure.

Why "Headroom" Matters

It is very important to give the CurePuck headroom which is can use to remove moisture inside the chamber as the flower cures down to the desired setpoint.

When the Room Is Too Dry

If the room is too dry this can also cause problem as well because now the pump has to turn on for very short durations since the drying power of the room is too strong, this will result in insufficient fresh air exchange or over drying if timed burps are used. Below 40% would be considered too low. The alarms can be set to alert you of room conditions going out of spec for temperature and humidity limits.

In summary:

- The CurePuck depends on your room as its drying engine.
- For AutoCure to work effectively, your room RH must be lower than the chamber target - otherwise, it simply can't finish the job.

HYDRATE MODE - AUTOCURE

The AutoCure algorithm is a bidirectional controller, meaning it can both remove and add moisture to maintain your target curing environment.

Starting Point: **Properly Dried Flower**

In a proper cure, you start with flower that has been dried in your dry room to a slightly higher moisture content than your final target.

Gradual Moisture Adjustment

From there, AutoCure gradually removes moisture and equalizes to reach the desired finish without over-drying.

Why Over-Drying Matters

As explained earlier, once moisture is lost from inside the trichomes, it can't be replaced. This is why it's so important not to over-dry prior to curing in the first place.

Hydrate Mode (Safety Net for Over-Dried Flower)

However, if for some reason the flower has been accidentally over dried, AutoCure has a Hydrate Mode that can carefully add moisture back to the organic material of the flower only (not the trichomes themselves). This can help restore weight and softness.

When Hydrate Mode Activates

Hydrate Mode works automatically when AutoCure is enabled, but only when two conditions are met:

- The room air must be more humid than the chamber, and
- The chamber moisture needs to rise to reach the target setpoint (whether %RH or VPD).

Practical Example

If your target is 58% RH, but the chamber has drifted down to 55% RH, and the room is at 60% RH, AutoCure will allow small amounts of humid air into the chamber to gently bring it back up to the target of 58%.

When Hydrate Mode Will NOT Start

If the room is too dry, Hydrate Mode will not activate. This ensures that moisture is only added when it is safe and necessary.

The Core Principle

It's the same idea as before of providing the CurePuck head room with the room conditions to drive the moisture inside the chamber gently in the direction you want it.

EXAMPLE VPD SET POINTS

Setpoint Room Temperature Range

VPD (kPa)	Low		Max		Avg		Avg %RH	Min %RH	Max %RH
	(°C)	(°F)	(°C)	(°F)	(°C)	(°F)			
1.268	23	73.4	25	77	24	75.2	57.5	55	60
1.194	22	71.6	24	75.2	23	73.4	57.5	55	60
1.124	21	69.8	23	73.4	22	71.6	57.5	55	60
1.057	20	68	22	71.6	21	69.8	57.5	55	60
0.994	19	66.2	21	69.8	20	68	57.5	55	60
0.877	17	62.6	19	66.2	18	64.4	57.5	55	60
0.824	16	60.8	18	64.4	17	62.6	57.5	55	60

Note:

It is better to err on the side of caution and pick a higher VPD number if you are not confident in your room's ability to maintain a cooler temperature range. The cooler temperatures will give you a less aggressive and gentler cure with better results.

This is also true for your room %RH, if it is closer to your setpoint the cure will be gentler and allows for more air exchange without over drying. If the room is too dry you will have fewer and shorter burps which will could result in inadequate air exchange. It is also important that your flower is correctly dried in the drying room prior to the curing process, starting a cure with flower that is too wet can also cause mold issues. The "flower too wet" alarm can be setup to alert you of these conditions.

VPD CALCULATOR

The VPD Calculator is a tool available at <https://curepuck.io/vpd-calculator> that helps determine an appropriate VPD setpoint when VPD is locked in **AutoCure Mode** (pages 8–10). Follow the instructions below to know the setpoint you need.

1-Set a Target RH.

2- Select the desired temperature units and adjust the temperature range of your room until the RH Mid lights up green.

The calculator will automatically calculate the resulting VPD value in kPa based on the entered parameters.

3-Enter the VPD setpoint into your CurePuck and enable Autocure VPD-Lock.

Note:The Max RH% is clamped to 60% by FunkGuard so if the room heats beyond your max temperature this can result in excess moisture venting.

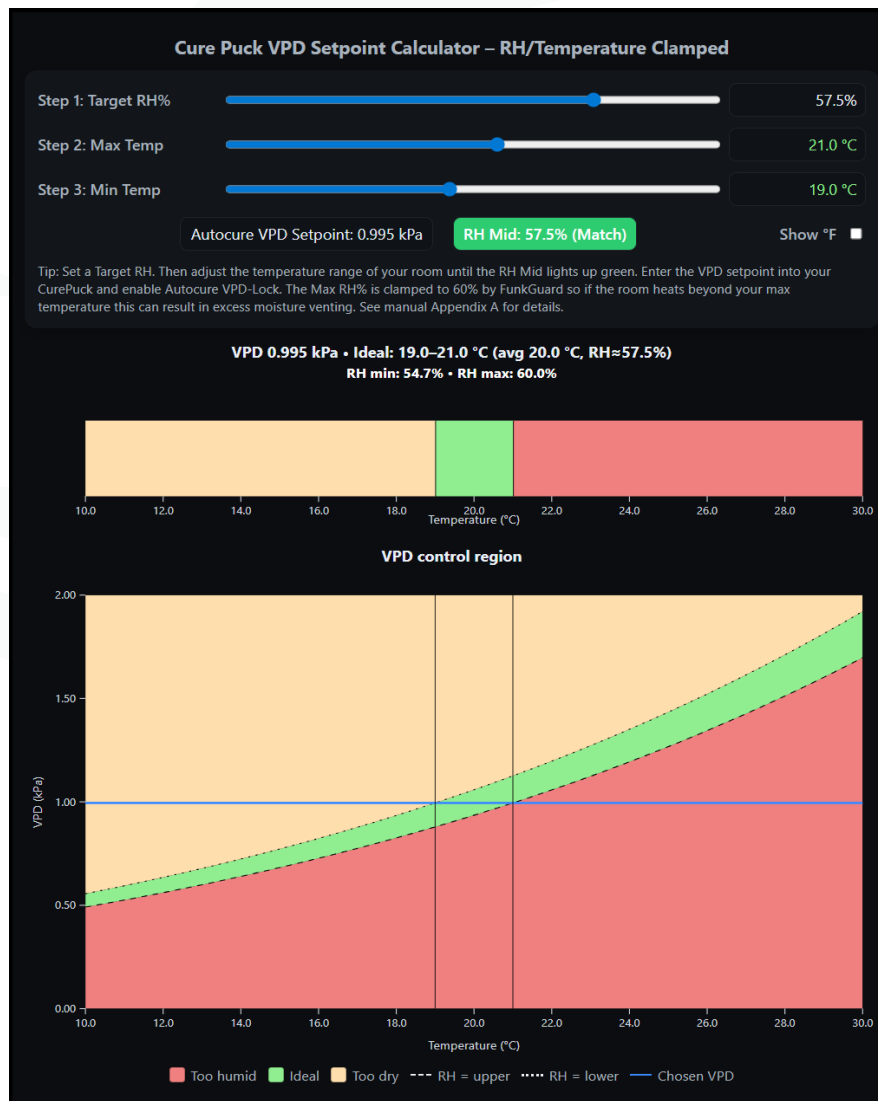

VPD vs TEMPERATURE vs %RH

The image below shows what happens to %RH while VPD is held constant and temperature rises, notice how %RH increase with temperature to maintain a constant VPD.

If the temperature in the room rises in such a way as to increase the %RH above the FunkGuard limit of 60%, VPD control will be temporarily disabled and a limit of 60%RH will be applied.

It is important to insure your VPD setting is adequate enough be under 60%RH for the maximum expected room temperature.

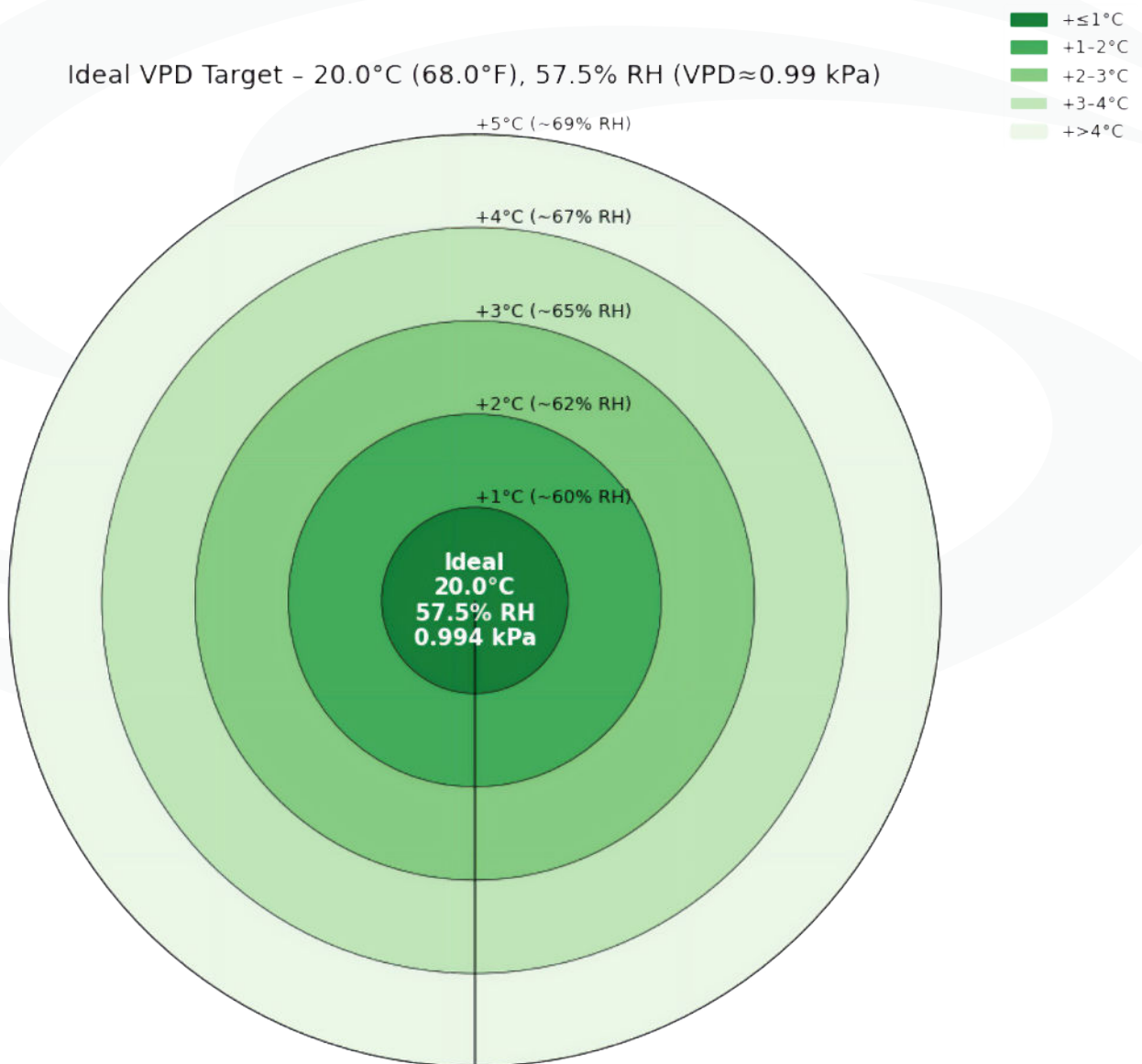

CURE **PUCK**

Keirton Technical Support is available between 7 a.m. and 7 p.m. Pacific Standard Time, seven days a week at:

- **1-888-254-3204**
- **support@keirton.com**